

## Precision Diode Digital Temperature For Up To 3 External Sensors

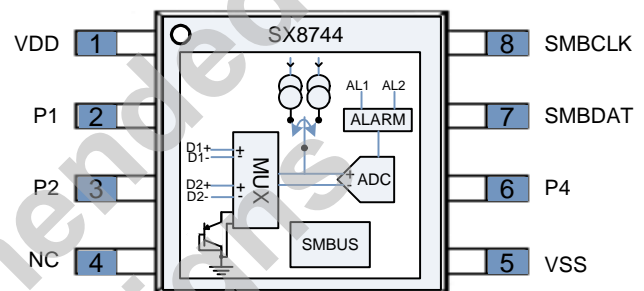
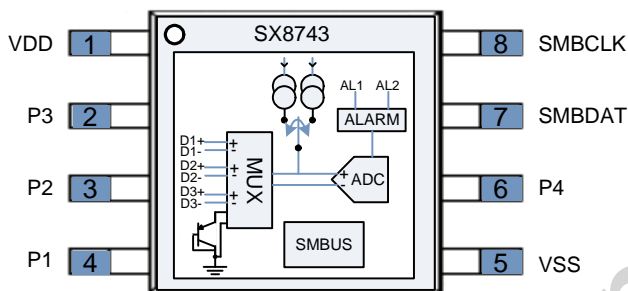
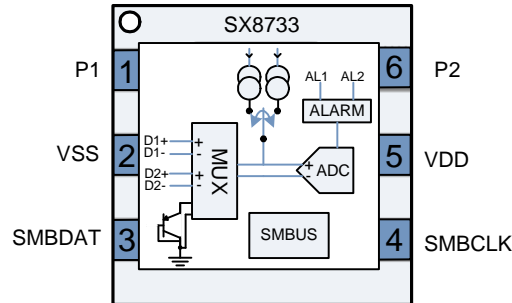

### General Description

The SX8733, SX8743 and SX8744 are digital temperature sensors with a 2-wire SMBus interface. It provides a low-cost solution to monitor the temperature of remote diodes as well as its own temperature with an on-chip PN junction sensor.

Depending on the device version, 2, 3 or 4 programmable ports are included. They offer the possibility to trig under- / over- temperature alarms which can be used as an interrupt or to connect up to 3 external sensors in single-ended mode or 2 external sensors in differential mode.

The parasitic resistances in series with the temperature monitoring diode can be cancelled by an algorithmic, a 3-point or a Kelvin (4-wire) method.

The SX8744 is pin-to-pin compatible with the LM86 part.

The SX8733 (2 programmable ports) is available in MLPD-6 package. The SX8743 (4 programmable ports) and SX8744 (3 programmable ports) are available in MSOP-8 package.

### Applications

- ◆ Printer
- ◆ Server
- ◆ Set Top Box
- ◆ Projector
- ◆ Batteries charger monitoring

### Key Product Features

- ◆ 1 Internal and Up To 3 External Sensors
- ◆ Remote Diode Temp. Accuracy of  $\pm 0.5^{\circ}\text{C}$  on the Temp. Range  $25^{\circ}\text{C}$  to  $100^{\circ}\text{C}$
- ◆ 2 Temp. Output Formats:  $0^{\circ}\text{C}$  to  $127^{\circ}\text{C}$  and  $-40^{\circ}\text{C}$  to  $140^{\circ}\text{C}$  With  $0.125^{\circ}\text{C}$  Resolution
- ◆ Parasitic Series Resistance Cancellation: Algorithmic, 3-point and Kelvin (4-wire)
- ◆ Under- / Over- Temp. Alarms With Programmable Thresholds
- ◆ Programmable Conversion Rate For Optimal Power Consumption
- ◆  $250\ \mu\text{A}$  Active Current @  $10\text{Hz}$  Sampling Rate
- ◆ SMBus v2.0 Interface Supports TIMEOUT
- ◆ Pb-Free, Halogen Free, RoHS/WEEE Compliant Product

### Ordering Information

Part Number	Feature	Package
SX8733EWLTRT	2 Programmable ports	MLPD-6
SX8743EMSTRT	4 Programmable ports	MSOP-8
SX8744EMSTRT	3 Programmable ports	MSOP-8

**Table of contents**

Section	Page
1. Electrical Characteristics .....	3
1.1. Sensor Temperature Definition .....	3
1.2. Absolute Maximum Ratings .....	3
1.3. Electrical Specification .....	4
1.4. SMBus Timing Characteristics .....	5
1.5. SMBus Timing Waveforms .....	5
2. Pin Configuration .....	6
2.1. Pinout .....	6
2.2. Pin Description .....	6
3. Configuration .....	7
3.1. General Presentation .....	7
3.2. Modes .....	7
3.3. Differential and Single-Ended External Sensor .....	10
3.4. Measurement Principle .....	10
3.5. Parasitic Track Resistance Cancellation .....	10
3.5.1. Algorithmic Track Resistance Cancellation .....	10
3.5.2. 3-Point Track Resistance Cancellation .....	10
3.5.3. The Kelvin (4-wire) Track Resistance Cancellation .....	11
3.6. Temperature Acquisition Sequence .....	11
3.7. Alarm .....	12
3.8. Temperature Data Format .....	12
3.9. Continuous Time Vs. Single Shot .....	13
4. Application Note .....	13
4.1. Typical Temperature Sensing System With A SX8743 .....	13
5. Power-Up Sequence and Standby Mode .....	14
6. Serial Interface .....	15
6.1. Register Write - Combined Format .....	15
6.2. Register Write - Direct Format .....	15
6.3. Register Read - Combined Format .....	15
6.4. Register Read - Direct Format .....	16
6.5. Soft Reset .....	16
7. Register / Memory Map .....	17
7.1. Memory Map .....	17
7.2. Registers Description .....	17
8. Packaging Information .....	21
8.1. MLPD-W6-EP2 Package Outline Drawing .....	21
8.2. MLPD-W6-EP2 Land Pattern Drawing .....	22
8.3. Package Outline Drawing: MSOP-8 .....	23
8.4. Land Pattern Drawing: MSOP-8 .....	24

## 1. Electrical Characteristics

### 1.1. Sensor Temperature Definition

Parameter	Symbol
Local sensor diode temperature (chip junction temperature)	$T_J$
External diode temperature (remote diode junction temperature)	$T_D$

### 1.2. Absolute Maximum Ratings

Stresses above the values listed below may cause permanent device failure. Exposure to absolute maximum ratings for extended periods may affect device reliability. Operation outside the parameters specified in the Electrical Characteristics section is not implied.

Parameter	Symbol	Conditions	Min	Max	Unit
Power supply to VSS	$V_{DD,ABSMAX}$		-0.5	5.75	V
Storage temperature	$T_{J,STORE}$		-50	150	°C
Ambient operating temperature	$T_{J,ABSMAX}$		-40	140	°C
Input voltage on programmable pin	$V_{PIN,ABSMAX}$	P1, P2, P3, P4	-0.5	$V_{DD} + 0.25$	V
Input voltage on SMBUS pin	$V_{PIN,SMBUS}$	SMBCLK, SMBDAT	-0.5	5.75	V
Input current on any pin	$I_{PIN,ABSMAX}$		-10	10	mA
Peak reflow temperature	$T_{PKG}$			260	°C
Latchup	$I_{LUP}$		-100	100	mA
ESD	HBM	Human Body Model		2	kV
	MM	Machine Model		200	V
	CDM	Charged Device Model		500	V

**ADVANCED COMMUNICATIONS & SENSING**
**DATASHEET**
**1.3. Electrical Specification**

All values valid within the operating conditions unless otherwise specified.

Parameter	Symbol	Conditions	Min	Typ	Max	Unit
<b>Operating Conditions</b>						
Power supply	$V_{DD}$		2.7	3.3	5.5	V
Power supply rise time <sup>1</sup>	$t_{rise25}$	$T_J = 25^\circ\text{C}$			1	ms
Power supply rise time <sup>1</sup>	$t_{rise125}$	$T_J = 125^\circ\text{C}$		0.5		ms
Operating temperature	$T_J$	Operating temperature = Junction temperature	-40		125	$^\circ\text{C}$
<b>Current Consumption</b>						
Active current	$I_{VDD,ACTIV E}$	10 Hz sampling rate No track cancellation mode		250	400	$\mu\text{A}$
Current in standby mode	$I_{VDD,STDBY}$			10	40	$\mu\text{A}$
<b>Temperature to Digital Converter</b>						
Temperature resolution	$T_{RESOL}$			0.125		$^\circ\text{C}$
Remote temperature error <sup>2</sup>	$T_{D,ERR1}$	$T_J = 25^\circ\text{C}$ to $85^\circ\text{C}$ $T_D = 25^\circ\text{C}$ to $100^\circ\text{C}$	-1.5	$\pm 0.5$	1.5	$^\circ\text{C}$
	$T_{D,ERR2}$	$T_J = 25^\circ\text{C}$ to $85^\circ\text{C}$ $T_D = -40^\circ\text{C}$ to $125^\circ\text{C}$	-3	$\pm 1.5$	3	$^\circ\text{C}$
Local temperature error <sup>2</sup>	$T_{J,ERR1}$	$T_J = 25^\circ\text{C}$ to $85^\circ\text{C}$	-2	$\pm 0.75$	2	$^\circ\text{C}$
	$T_{J,ERR2}$	$T_J = -40^\circ\text{C}$ to $125^\circ\text{C}$		$\pm 1.5$		$^\circ\text{C}$
Conversion time	$t_{CONV}$	10Hz sampling rate		100		ms
Remote-diode source current	$I_2$	High level		100		$\mu\text{A}$
	$I_1$	Low level		10		$\mu\text{A}$
Alarm output low voltage	$V_{OL,AL}$	$I_{OL} < 4\text{mA}$			0.4	V
Leakage current	$I_{D,LEAK}$	Standby mode	-1		1	$\mu\text{A}$
<b>SMBus - Compatible Interface SMBCLK &amp; SMBDAT</b>						
Input logic high	$V_{IH}$		2.1			V
Input logic low	$V_{IL}$				0.8	V
Output logic low	$V_{OL}$	$I_{OL} < 4\text{mA}$			0.4	V
Current leakage on SMBCLK/SMBDAT	$I_{LEAK,SMB}$		-1		1	$\mu\text{A}$
Capacitive load on SMBCLK/SMBDAT	$C_{BUS}$			5		pF

1. See Figure 10

 2. Specification with  $V_{DD}=3.0\text{V}$  to  $3.6\text{V}$  and track resistance cancellation disabled.

**1.4. SMBus Timing Characteristics**

Parameter	Symbol	Conditions	Min	Typ	Max	Unit
SMBus clock frequency	$f_{\text{SMB}}$		10		400	kHz
SMBus clock low time	$t_{\text{LOW}}$		1.3			us
SMBus clock high time	$t_{\text{HIGH}}$		0.6			us
SMBus rise time	$t_{\text{R,SMB}}$				300	ns
SMBus fall time	$t_{\text{F,SMB}}$				300	ns
SMBDAT and SMBCLK time low for reset of serial interface	$t_{\text{TIMEOUT}}$		25		35	ms
Data setup time	$t_{\text{SU,DAT}}$		100			ns
Data hold time <sup>1</sup>	$t_{\text{HD,DAT}}$		0			ns
Start condition hold time (SMBDAT low to SMBCLK low)	$t_{\text{HD,STA}}$		0.6			us
Stop condition hold time (SMBCLK high to SMBDAT high)	$t_{\text{SU,STO}}$		0.6			us
Repeated start-condition setup time (SMBCLK high to SMBDAT low)	$t_{\text{SU,STA}}$		0.6			us
SMBus free time between stop and start conditions	$t_{\text{BUF}}$		1.3			us

1. The device provides a hold time of at least 300ns for the SMBDAT signal to bridge the undefined region of the falling edge of SMBCLK.

**1.5. SMBus Timing Waveforms**

Figure 1. SMBUS Timing

## 2. Pin Configuration

### 2.1. Pinout

Pin #	SX8733 <sup>1</sup>	SX8743	SX8744
1	P1	VDD	VDD
2	VSS	P3	P1
3	SMBDAT	P2	P2
4	SMBCLK	P1	NC
5	VDD	VSS	VSS
6	P2	P4	P4
7	-	SMBDAT	SMBDAT
8	-	SMBCLK	SMBCLK

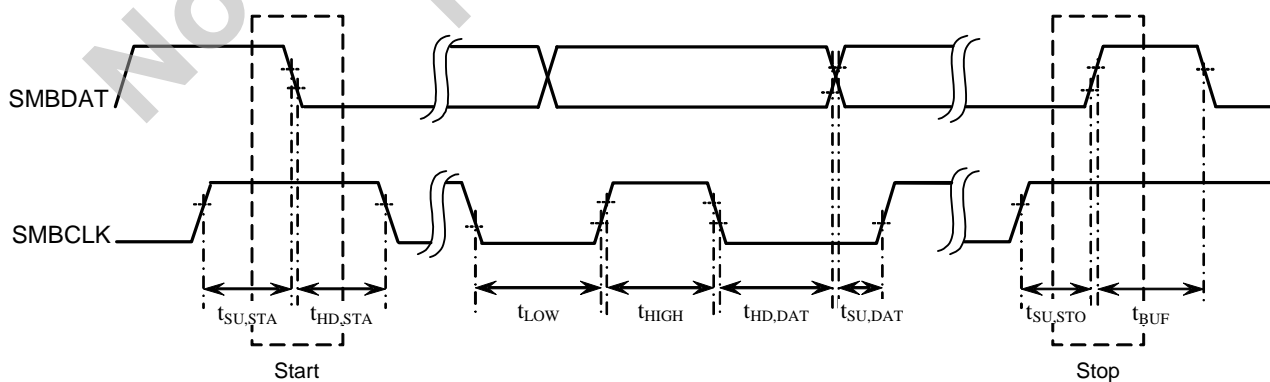
1. MLPD exposed pad is not connected internally. It is connected to ground plane for thermal dissipation

Table 1 Pinout

### 2.2. Pin Description

Pin	Type	Description
SMBCLK	DIGITAL	SMBus serial clock input, open drain
SMBDAT	DIGITAL	SMBus serial data input/output, open drain
VDD	POWER	Positive power supply
VSS	POWER	Negative power supply

Table 2 Power and SMBus Pin Description

Pin	Type	Description	Mode												
			0 1	2	3	4 5	6 7	8 9	10	11 12	13 14	15	16 17	18	20
P1	ANALOG	Ext. diode current source	D1+	D1+		D1+	D1+	D1+	D1+	D1+	D1+	D1+	D1+	D1+	D1+
	DIGITAL	Alarm output, pseudo-open drain			AL1										
P2	ANALOG	Ext. diode current source				D2+						D2+	D2+	D2+	
	ANALOG	Ext. diode return current sink	D1-	D1-				D1-	D1-	D1-				D1-	
P3	DIGITAL	Alarm output, pseudo-open drain			AL2		AL1								
	ANALOG	Ext. diode return current sink								D2+	D2+		D3+	D3+	D1+
P4	ANALOG	Ext. diode return current sink										D1-	D2-		
	DIGITAL	Alarm output, pseudo-open drain						AL1	AL1						
VSS	POWER	Ext. diode return current sink													
				D1-		D1-	D1-		D1-		D1-	D1-	D1-	D1-	D1-

Table 3 Programmable Pin Description

## 3. Configuration

### 3.1. General Presentation

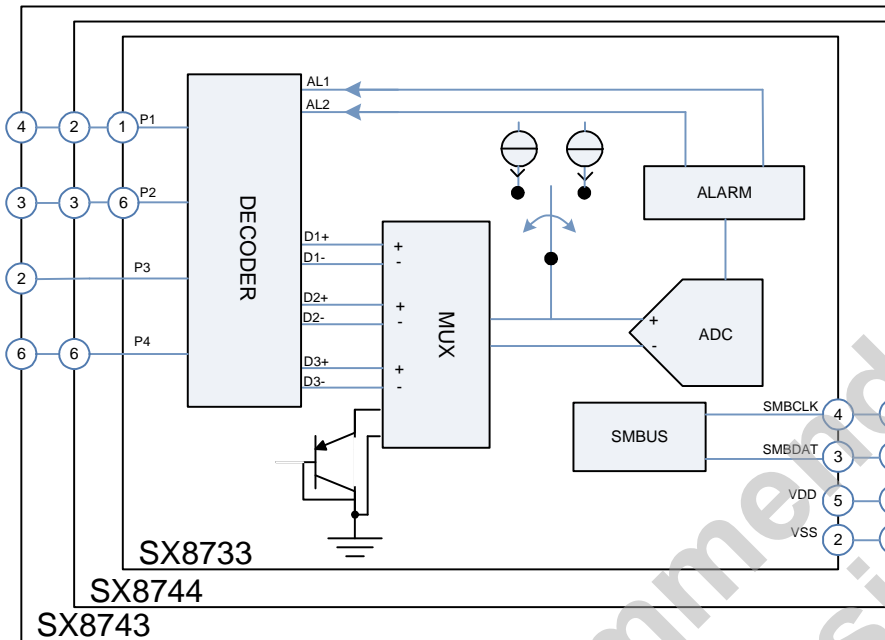

SX8733 / SX8743 / SX8744 include an on-chip PN junction to measure local temperature  $T_J$ .

The device has a 2-level current source and an ADC to measure each diode's forward voltage to compute the temperature. The input multiplexer allows 3 external and 1 internal sensors to be connected to the ADC.

Two alarms can provide to the system the information that a sensor temperature has reached the programmable threshold.

The chip is configured with a 2-wire SMBUS serial line.

The functional diagram is shown in Figure 2.

Figure 2. Functional Diagram

### 3.2. Modes

The mode set in *RegConfig* allows numerous circuit configurations described in Figure 3 and Figure 4.

Up to 3 external sensors can be connected. These are configured with differential or single-ended connections.

Some modes provide a track resistance cancellation feature to decrease temperature inaccuracy linked to long PCB traces connecting the external sensor to the chip. This is set in *RegControl* (bits *Point3* or *Algo*). Table 4 presents the mode for the SX8743.

Mode	0	1	2	3	4	5	6	7	8	9	10	11	12	13	14	15	16	17	18	20
External sensor	1	1	1	0	2	2	1	1	1	1	1	2	2	2	2	2	3	3	3	1
Differential	x	x							x	x		x	x							x
Single-ended			x		x	x	x	x			x			x	x	x	x	x	x	
Algorithmic track resistance cancellation		x				x		x		x			x		x				x	
3-point track resistance cancellation			x								x					x				x
Kelvin (4-wire) track resistance cancellation																				x
Alarm #	0	0	0	2	0	0	1	1	2	2	2	0	0	2	2	1	1	1	0	0

Table 4 Features Available With SX8743

Due to their limited number of ports, SX8733 and SX8744 do not offer all these features. SX8733 does not provide ports P3 and P4 so modes 8 to 20 should not be used. Also port P3 is not available on SX8744 and this typically reduces the number of alarm or the number of external sensors.

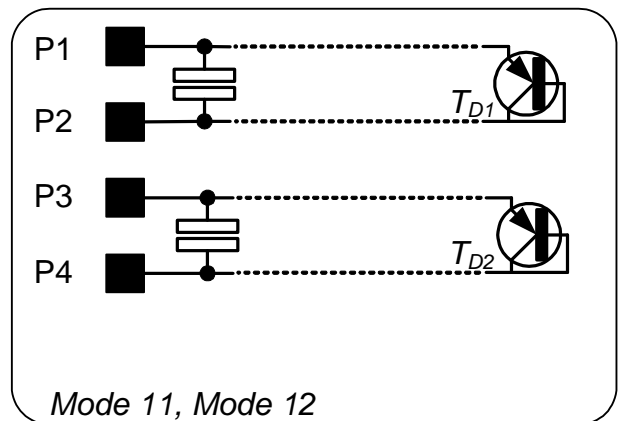
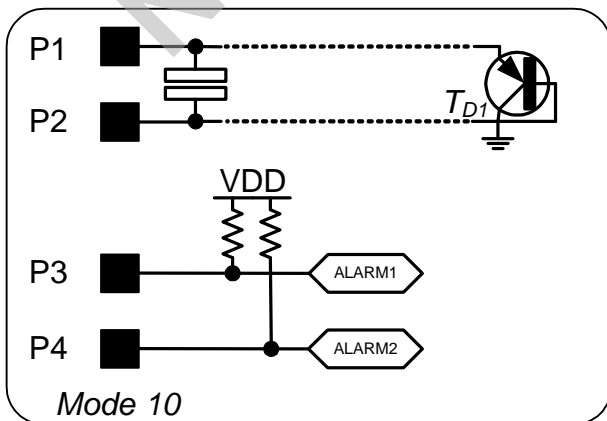
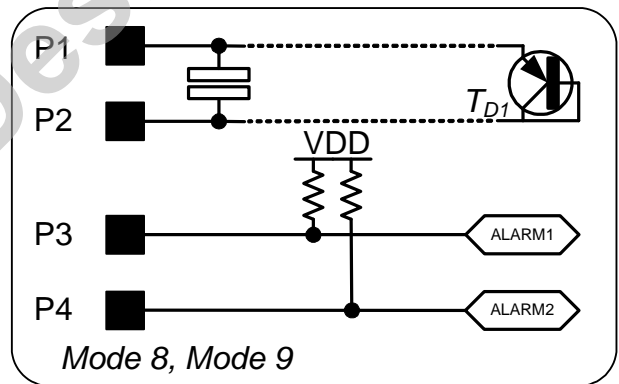
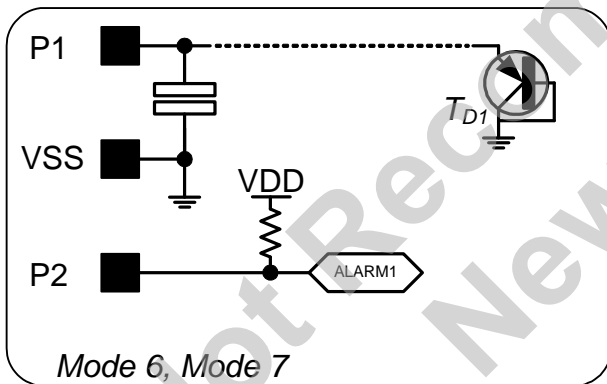
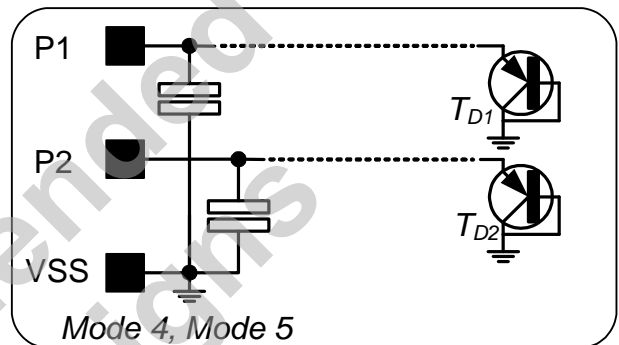
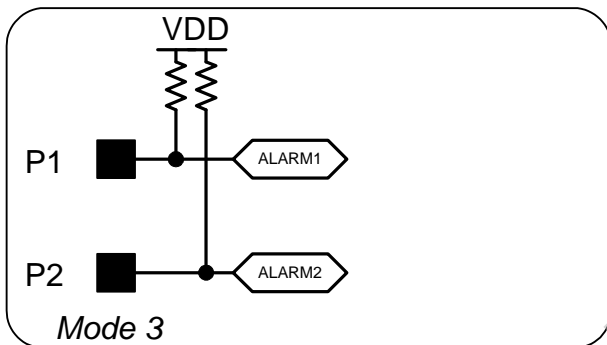
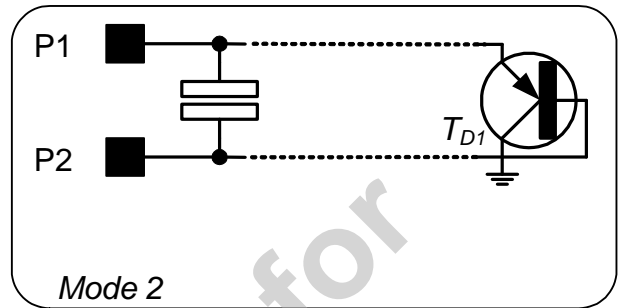
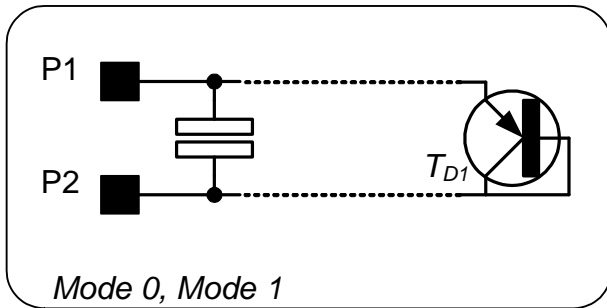

Figure 3. Mode Connection Diagrams (Modes 0 to 12)



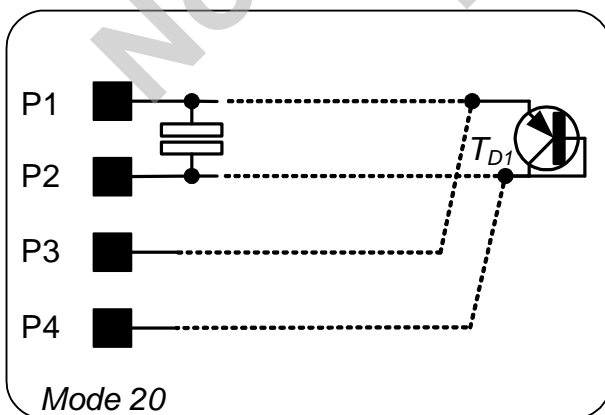
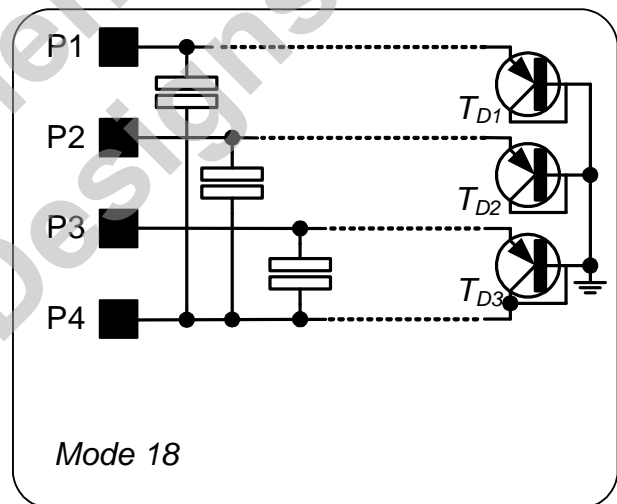
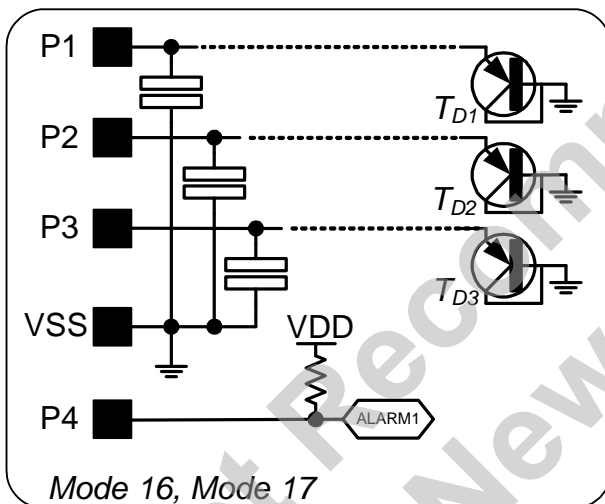
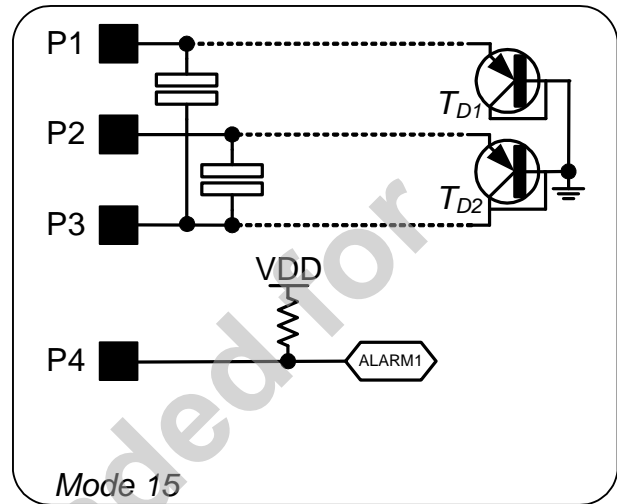
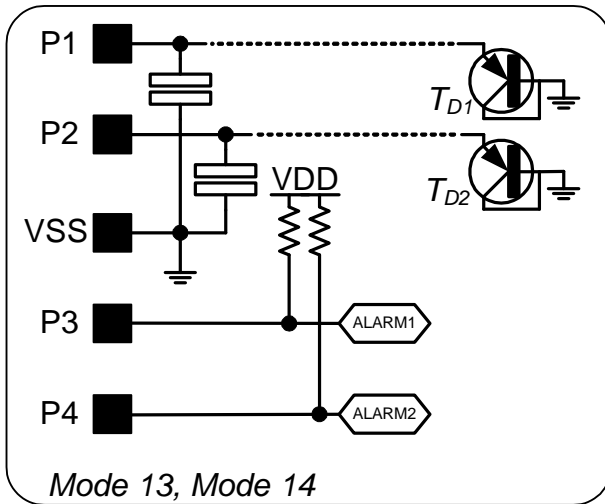

Figure 4. Mode Connection Diagrams (Modes 13 to 18 and 20)

### 3.3. Differential and Single-Ended External Sensor

Table 4 indicates whether the external sensors are connected differentially or in single-ended configuration with grounded cathode.

Differential modes have better common-mode rejection of external noise pickup. The external noise pickup is present equally on the anode and the cathode therefore differential noise is minimized.

Single-ended modes allow more sensors to be connected to the chip but they are more prone to noise pickup since the cathode is connected to a common VSS and, therefore, any external noise pickup tends to be developed mainly across the anode which will be measured as temperature noise.

A filtering capacitor is recommended to decrease measurement noise especially if the external sensor is connected to the chip by a long trace. A capacitor with a value of 100 pF should be placed as close as possible to the chip pins.

### 3.4. Measurement Principle

The circuit uses the intrinsic thermal property of a diode to measure temperature. Temperature is calculated by measuring the base-emitter voltage of a transistor. Two different currents are sourced to the diodes. The base-emitter voltage is measured in each case. With a fixed current ratio, temperature is accurately calculated by measuring the difference in the base-emitter voltage at the two currents.

The excitation current  $I_2$  of 100uA is passed through the diode first. The base-emitter voltage of the transistor is measured by the ADC. The measurement is then repeated using the excitation current divided by a fixed value. This current  $I_1$  has a value of 10uA. The following equation relates the  $V_{BE}$  difference voltage with current and temperature T where:

- ◆ k is the Boltzmann's constant ( $1.381 \times 10^{-23}$  J/K)
- ◆ q is the charge on the electron ( $1.602 \times 10^{-19}$  Cb).
- ◆  $T_{abs}$  is the absolute temperature in Kelvins. ( $T_{abs}=273.15 + T$  where T is the temperature in Celsius).
- ◆ n is the pn junction ideality factor (1.00 for an ideal diode)

$$\Delta V_{BE} = V_{BE2} - V_{BE1} = n \cdot \frac{kT_{abs}}{q} \ln\left(\frac{I_2}{I_1}\right)$$

For a current ratio  $I_2/I_1=10$  and an ideality factor  $n=1.010$ , this gives a fixed relationship between  $\Delta V_{BE}$  and temperature of 200uV/°C. The voltage is then converted to digital with an ADC.

### 3.5. Parasitic Track Resistance Cancellation

The temperature measurement method described previously assumes a very low series impedance in the sensor path. With a typical  $\Delta V_{BE}$  around 200uV/°C and the  $\Delta I=I_2-I_1=90\mu A$ , 1 ohm of parasitic resistance in the sensor path gives approximately 0.45°C of temperature error. This may result in a significant error if the external sensor is located some distance away from the chip. Track resistance cancellation schemes decrease temperature error due to high resistance in the tracks from the device to the sensors.

$$\Delta T_{Rtrack} = R_{Track} \cdot \frac{I_2 - I_1}{200\mu V/C}$$

#### 3.5.1. Algorithmic Track Resistance Cancellation

The use of the algorithmic track resistance cancellation allows automatic cancellation of resistances in series with the temperature diode by using current modulation to bias the external diode. This is done transparently to the user. This method may cancel up to 1 kOhm of series resistance. The best accuracy is in the  $T_D$  range 20°C to 70°C.

#### 3.5.2. 3-Point Track Resistance Cancellation

The 3-point track resistance cancellation requires one additional connection to the external PN junction so that an additional current source can be used to cancel out the error voltage due to the track resistance.

Track resistances up to 1 kOhm may be cancelled. It is important that the track resistance values in the cathode or anode path of the external sensor are made equal. Care must be taken during PCB layout to match track resistances between the device and the sensor. Any resistance difference will lead to cancellation errors.

In this mode, VSS is used for the current return path from the cathode. This connection must be placed close to the diode's cathode. One port supply the current modulation to the anode and another port supply the cancellation current to the cathode. The resulting junction voltage modulation is measured between the 2 used ports. Figure 5 explains the method:

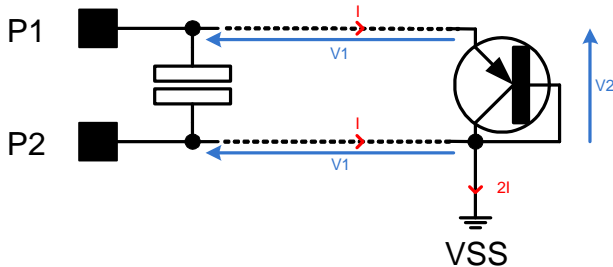

Assume sensor Q1 is being measured in mode 2 with 3-point track resistance cancellation enabled. The PCB trace linking the device to the external sensor must be matched which means the PCB track resistance are the same. The same current is forced out of P1 and P2.

The voltages developed on P1 and P2 traces are the same therefore the differential voltage seen on P1-P2 is not impacted by the track resistance.

Figure 5. 3-Point Track Resistance Cancellation

### 3.5.3. The Kelvin (4-wire) Track Resistance Cancellation

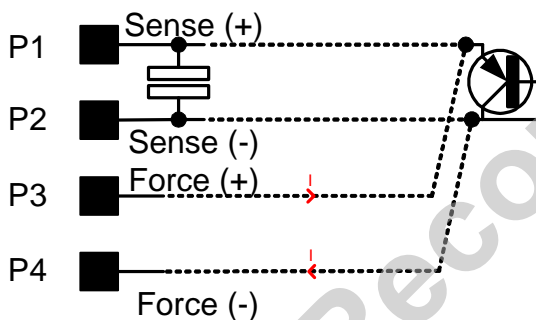

The sensor is connected to the chip via 4 wires. Two comes from the current source (force : P3, P4) and two are used for the voltage measurement (sense : P1, P2).

The Kelvin connection avoids the measurement error caused by the voltage drop in the force path.

Sense leads are attached directly across the external sensor. The P1 and P2 connections must be as close as possible to sensor anode and cathode respectively.

Figure 6. Kelvin (4-wire) Track Resistance Cancellation

### 3.6. Temperature Acquisition Sequence

The SX8743 monitors up to 4 sensors (3 remote and 1 internal). These can be scanned in sequence to make an automatic reading of the sensors one after the other. The result of each conversion is stored in the temperature registers (see Table 6). The register *RegSensor* defines which sensors are scanned in the sequence. When all the sensors are selected, the sequence is the following: Int→ Ext1→ Ext2→ Ext3→Int→etc.

### 3.7. Alarm

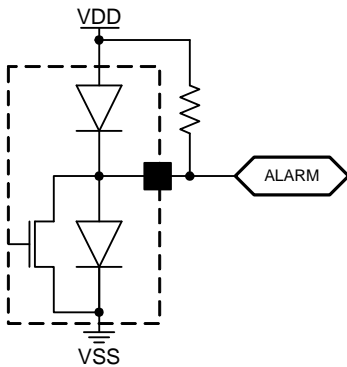

Alarm threshold registers (*RegAlarm1* and *RegAlarm2*) contain the value the user wishes the alarms to trip on. The alarm data format is the same as the temperature data format which is set in *RegControl* (bit *TempOffsetMode*). In other words, in binary mode alarm value is set in degree; in offset binary mode alarm is set in with an offset of 64. The alarm calculation is performed at the end of the temperature sensing cycle. Therefore, if *TempOffsetMode* bit or alarm values are changed, a temperature sensor measurement must be run to update the alarm outputs.

Depending on the selected mode, the chip can have two alarm outputs: Alarm1 and Alarm2. If the external or internal temperature exceeds or goes under a programmed temperature threshold, the alarm is activated. Any remote or local sensor may be selected to trigger Alarm1 and Alarm2.

Figure 7. Alarm Output Internal Simplified Schematics

The pseudo-open drain output shown in Figure 7 requires a pull-up resistor connected to VDD. It allows connection to a GPIO, a system shutdown or other thermal management circuitry.

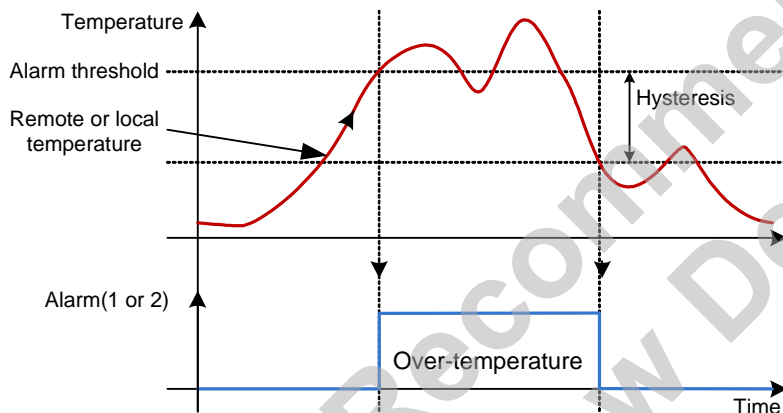

The alarm polarity can be set active low or high and, the over or under temperature can also be set with *RegAlarmSet* register.

To prevent alarm outputs to trig constantly when the limit temperature is reached, the *RegAlarmHyst* register holds a hysteresis value. The alarm remains active while the temperature is superior to the alarm threshold minus the value programmed in the *RegAlarmHyst* register (for a trig on over-temperature) as described on Figure 8.

Figure 8. Alarm Output

### 3.8. Temperature Data Format

Temperature output code from the internal and external sensors are made of 2 bytes. The temperature high byte has an LSB representing 1°C and contains the integer part of the temperature while the low byte contains the fractional value with a resolution of 0.125°C.

The SX8733 has 2 temperature data formats. By default, the format is binary and the measurement range is from 0°C to 127°C. To extend the measurement range to -40°C to +140°C, an offset of 64°C is added to the binary code.

When a conversion is complete, the main temperature register and the extended temperature register are updated simultaneously. Ensure that no conversions are completed between reading the main register and the extended register, so that both registers contain the result of the same conversion.

Temperature High Byte			Temperature Low Byte	
Temperature (°C)	Binary	Offset Binary <sup>1</sup>	Temperature (°C)	Binary or Offset Binary
-40 or less	0000 0000 <sup>2</sup>	0001 1000	x.000	0000 0000
0	0000 0000	0100 0000	x.125	0000 0001
1	0000 0001	0100 0001	x.250	0000 0010
50	0011 0010	0111 0010	x.375	0000 0011
64	0100 0000	0000 0000	x.500	0000 0100
100	0110 0100	1010 0100	x.625	0000 0101
127	0111 1111	1011 1111	x.750	0000 0110
140 or more	0111 1111 <sup>3</sup>	1100 1100	x.875	0000 0111
Diode fault	1111 1111 <sup>4</sup>	1111 1111 <sup>4</sup>		

- Offset binary scale temperature values are offset by 64°C
- Binary scale returns 0°C for all temperatures <0°C
- Binary scale returns 127°C for all temperatures >127°C
- A diode fault is detected when the temperature ADC hard limits at 0% or 100% pulse density

### 3.9. Continuous Time Vs. Single Shot

The chip can be operated in 2 distinct modes: continuous time or one-shot.

The one-shot mode performs one temperature measurement of all sensors selected in *RegSensor*. After completion, it returns to standby.

In continuous temperature sampling, temperature measurements are taken at regular intervals and the result held in internal registers accessible by SMBUS. The *RegADCRate* register controls the sampling time period.

## 4. Application Note

### 4.1. Typical Temperature Sensing System With A SX8743

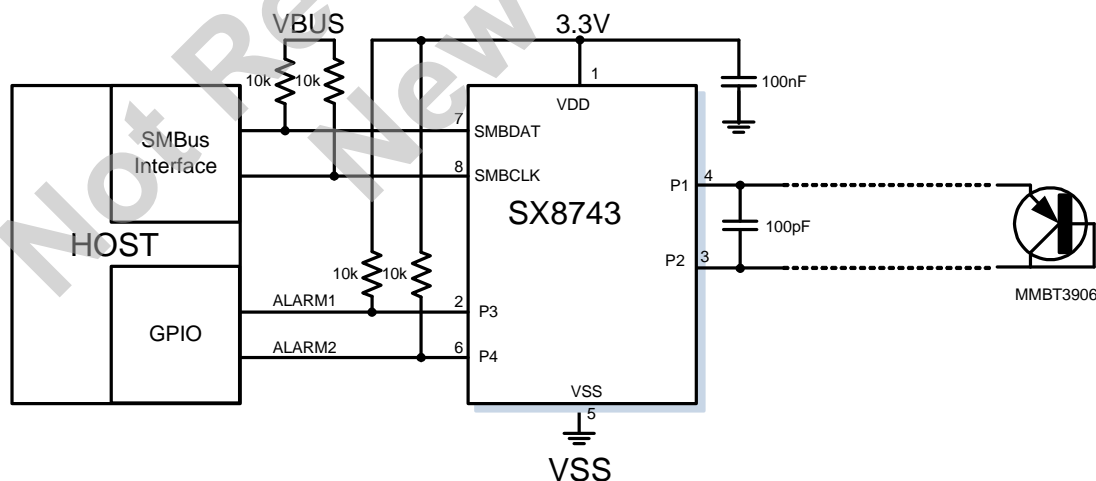

Figure 9. SX8743 Performs Remote Temperature Measurement In Mode 8

When the remote-sensing diode is a discrete transistor, its collector and base should be connected together. An external capacitor of 100pF across the PN junction smoothes out external noise interference. The capacitor must be located very close to the pins.

The ideality factor is a measure of the deviation of the thermal diode from ideal behavior. The chips are trimmed for the PNP device described in Table 5.

A different ideality factor causes a change in the slope of the linear equation  $\Delta V_{BE}=f(T)$ .

Gain and offset can be adjusted with the registers *RegExtGain* and *RegExtOffset* to compensate for small variations in n. Large power transistors must not be used.

$$\Delta T_{nfact} = \left( \frac{n_{nom}}{n_{actual}} - 1 \right) \cdot (T_D + 273.15)$$

Part Number	Manufacturer	Package
MMBT3906	Fairchild	SOT23-3

Table 5 Recommended device

## 5. Power-Up Sequence and Standby Mode

A fast rise of the power supply at power-up is required to ensure a safe start. The rise time must meet the timing described in Figure 10

At power-up, the device is in one-shot mode waiting for an SMBUS command to start conversion.

The measurement interval and the alarm thresholds will default to a set value at power-up but may be reconfigured to different values with SMBUS command.

Between temperature measurements, to decrease power consumption, the chip will shut down into its low-power standby state with most functions disabled.

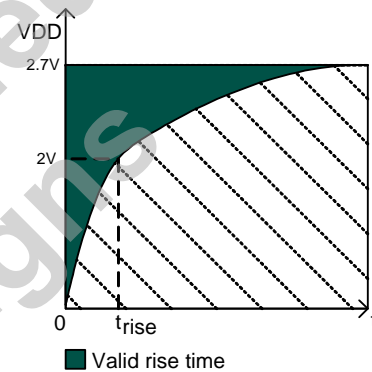
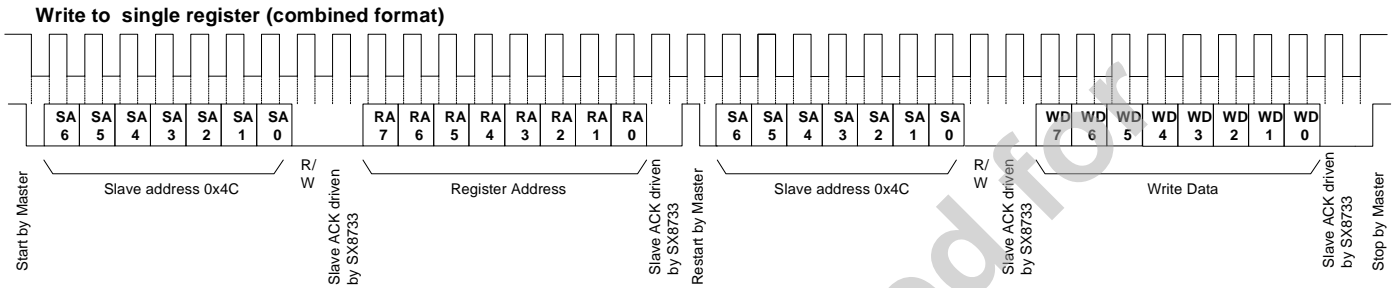

Figure 10. Power supply rise time

## 6. Serial Interface

### 6.1. Register Write - Combined Format



### 6.2. Register Write - Direct Format

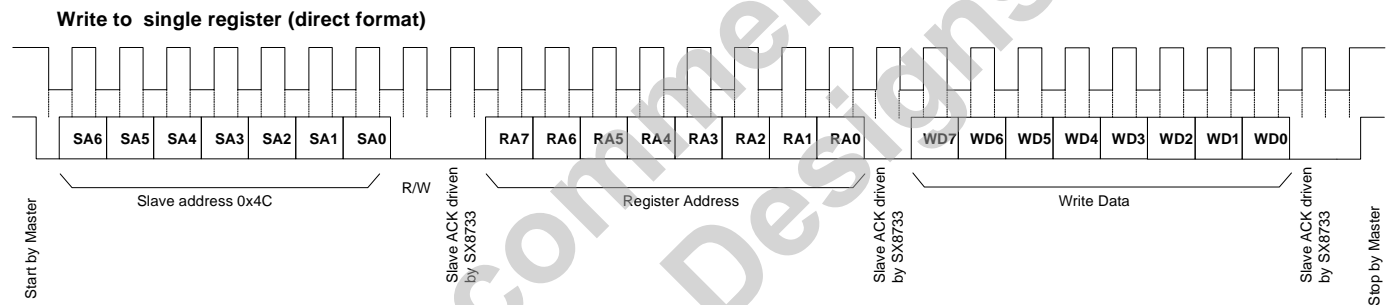

### 6.3. Register Read - Combined Format

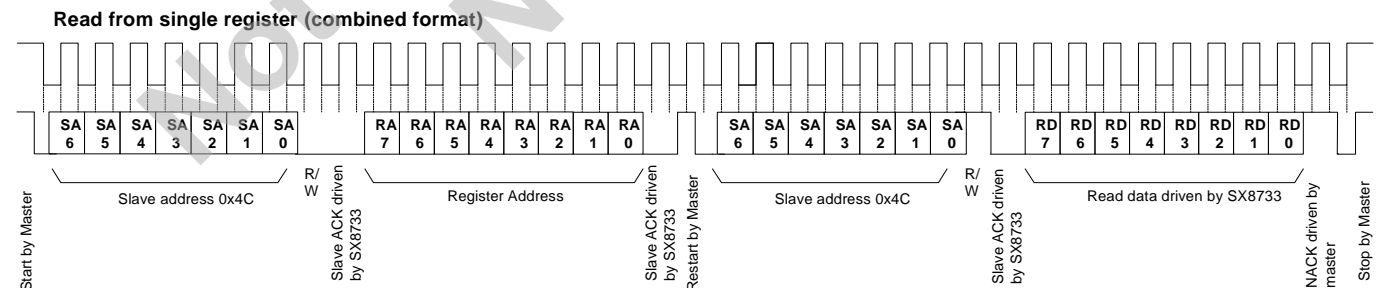

#### 6.4. Register Read - Direct Format

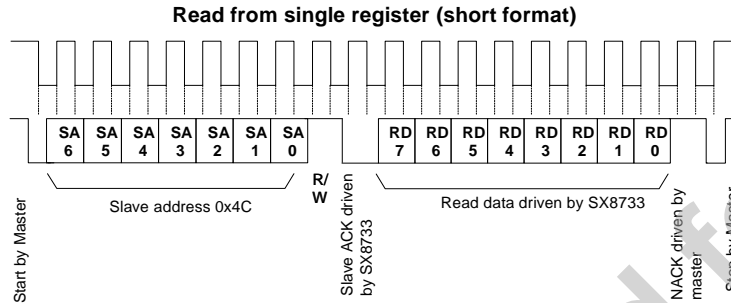

#### 6.5. Soft Reset

The user may reset the circuit via SMBus by sending a general call address at slave address 0x00 followed by the reset command 0x06. In other words, as illustrated in the figure below, a soft reset can be generated by sending a command at slave address 0x00 (rather than the regular 0x4C slave address) to IC register address 0x06 with any data (0xXX). The soft reset command sets the circuit and registers in the same state as after a power-up.

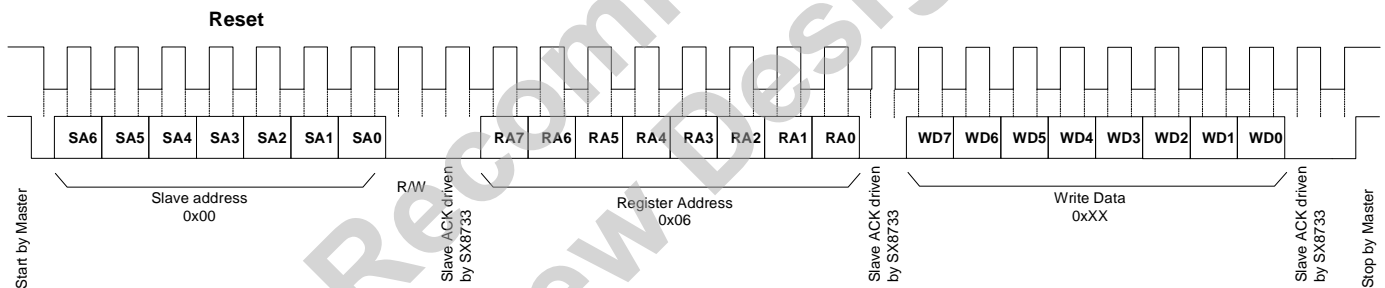



## 7. Register / Memory Map

Each register is described in the following register memory map. These are identified by a Register Name and corresponding hexadecimal register address.

### 7.1. Memory Map

Identification Registers		
0x00	RegConfig	Determines the chip variant and the communication interface (I2C or SMBus)
0x06	RegExtGain	Sets the calibration gain for remote temperature measurement
0x07	RegExtOffset	Sets the calibration offset for remote temperature measurement
0x20	RegDeviceID	Read-only ID = 0x33
0x21	RegDeviceVersion	Read-only circuit revision
Configuration Registers		
0x22	RegSensor	Defines which sensors are scanned in sequence
0x23	RegAlarm1	Alarm1 threshold
0x24	RegAlarm2	Alarm2 threshold
0x25	RegAlarmSet	Defines which sensors control alarms 1 and 2, and whether over-/under- temperature triggers for each alarm
0x26	RegAlarmHyst	Alarm hysteresis
0x27	RegADCRate	Temperature conversion rate
Temperature Registers		
0x28	RegIntTempMSB	$T_J$ temperature reading for internal sensor, integer part, LSB = 1°C
0x29	RegIntTempLSB	$T_J$ temperature reading for internal sensor, fractional part, LSB = 0.125°C
0x2A	RegExtTemp1MSB	$T_{D1}$ temperature reading for external sensor 1, integer part, LSB = 1°C
0x2B	RegExtTemp1LSB	$T_{D1}$ temperature reading for external sensor 1, fractional part, LSB = 0.125°C
0x2C	RegExtTemp2MSB	$T_{D2}$ temperature reading for external sensor 2, integer part, LSB = 1°C
0x2D	RegExtTemp2LSB	$T_{D2}$ temperature reading for external sensor 2, fractional part, LSB = 0.125°C
0x2E	RegExtTemp3MSB	$T_{D3}$ temperature reading for external sensor 3, integer part, LSB = 1°C
0x2F	RegExtTemp3LSB	$T_{D3}$ temperature reading for external sensor 3, fractional part, LSB = 0.125°C
General Registers		
0x30	RegControl	General Control register
0x31	RegStatus	General Status register

Table 6 Memory map

### 7.2. Registers Description

Addr: 0x00 RegConfig				
Bits	Name	Mode	Reset	Description
7:6	Reserved	rw	00	Write to 00
5	SetInterface	rw	1	Select between I2C or SMBus interface 0: I2C (Time Out Disabled) 1: SMBUS
4:0	Mode	rw	00000	Select the configuration mode 00000: Mode 0 00001: Mode 1 ... 10010: Mode 18 10100: Mode 20

**ADVANCED COMMUNICATIONS & SENSING**
**DATASHEET**
**Addr: 0x06 RegExtGain**

Bits	Name	Mode	Reset	Description
7:6	Reserved	rw	00	Write to 00
5:0	ExtGain	rw	xxxxxx	Gain adjustment for external temperature measurement Do not write to avoid production calibration altering

**Addr: 0x07 RegExtOffset**

Bits	Name	Mode	Reset	Description
7:0	ExtOffset	rw	xxxxxxx	Offset adjustment for external temperature measurement. Do not write to avoid production calibration altering

**Addr: 0x22 RegSensor**

Bits	Name	Mode	Reset	Description
7:4	Reserved	rw	0000	Write to 0000
3	SelExt3	rw	0	0: External sensor 3 not in temp. scan sequence 1: Enable external sensor 3 to be in temp. scan sequence
2	SelExt2	rw	0	0: External sensor 2 not in temp. scan sequence 1: Enable external sensor 2 to be in temp. scan sequence
1	SelExt1	rw	0	0: External sensor 1 not in temp. scan sequence 1: Enable external sensor 1 to be in temp. scan sequence
0	SelInt	rw	1	0: Internal sensor not in temp. scan sequence 1: Enable internal sensor to be in temp. scan sequence

**Addr: 0x23 RegAlarm1**

Bits	Name	Mode	Reset	Description
7:0	Threshold1	rw	01000000	Alarm1 temperature threshold. The data is coherent with the binary and offset format. 1LSB=1°C

**Addr: 0x24 RegAlarm2**

Bits	Name	Mode	Reset	Description
7:0	Threshold2	rw	01000000	Alarm2 temperature threshold. The data is coherent with the binary and offset format. 1LSB=1°C

**Addr: 0x25 RegAlarmSet**

Bits	Name	Mode	Reset	Description
7	Reserved	rw	0	Write to 0
6	AlarmPolarity	rw	0	0: Alarm1, Alarm2 outputs active high 1: Alarm1, Alarm2 outputs active low
5	Direction2	rw	0	0: Trigger on over-temperature for Alarm2 1: Trigger on under-temperature for Alarm2
4	Direction1	rw	0	0: Trigger on over-temperature for Alarm1 1: Trigger on under-temperature for Alarm1
3:2	Select2	rw	00	00: External 1 sensor controls Alarm2 01: External 2 sensor controls Alarm2 10: External 3 sensor controls Alarm2 11: Internal sensor controls Alarm2
1:0	Select1	rw	11	00: External 1 sensor controls Alarm1 01: External 2 sensor controls Alarm1 10: External 3 sensor controls Alarm1 11: Internal sensor controls Alarm1

**Addr: 0x26 RegAlarmHyst**

Bits	Name	Mode	Reset	Description
7:4	Hysteresis2	rw	0100	Defines Alarm2 hysteresis with 1°C resolution. (0 to 15°C)
3:0	Hysteresis1	rw	0100	Defines Alarm1 hysteresis with 1°C resolution. (0 to 15°C)

**ADVANCED COMMUNICATIONS & SENSING**
**DATASHEET**
**Addr: 0x27 RegADCRate**

Bits	Name	Mode	Reset	Description
7:5	Reserved	rw	000	Write to 000
4	OneShot	rw	0	0: Standby 1: Perform one temperature measurement
3	Regular	rw	0	0: Disable continuous temperature sampling 1: Enable continuous temperature sampling
2:0	Rate	rw	000	Temperature sampling rate 000: 0.1 second (continuous sampling) 001: 0.25 second 010: 0.50 second 011: 1 second 100: 2 seconds 101: 4 seconds 110: 8 seconds 111: 16 seconds

**Addr: 0x28 RegIntTempMSB**

Bits	Name	Mode	Reset	Description
7:0	IntTempMSB	r	00000000	MSB of Internal Temperature $T_J$ . LSB=1°C

**Addr: 0x29 RegIntTempLSB**

Bits	Name	Mode	Reset	Description
7:3	Reserved	r	00000	
2:0	IntTempLSB	r	000	LSB of Internal Temperature $T_J$ . LSB=0.125°C

**Addr: 0x2A RegExtTemp1MSB**

Bits	Name	Mode	Reset	Description
7:0	ExtTemp1MSB	r	00000000	MSB of External Temperature $T_{D1}$ . LSB=1°C

**Addr: 0x2B RegExtTemp1LSB**

Bits	Name	Mode	Reset	Description
7:3	Reserved	r	00000	
2:0	ExtTemp1LSB	r	000	LSB of External Temperature $T_{D1}$ . LSB=0.125°C

**Addr: 0x2C RegExtTemp2MSB**

Bits	Name	Mode	Reset	Description
7:0	ExtTemp2MSB	r	00000000	MSB of External Temperature $T_{D2}$ . LSB=1°C

**Addr: 0x2D RegExtTemp2LSB**

Bits	Name	Mode	Reset	Description
7:3	Reserved	r	00000	
2:0	ExtTemp2LSB	r	000	LSB of External Temperature $T_{D2}$ . LSB=0.125°C

**Addr: 0x2E RegExtTemp3MSB**

Bits	Name	Mode	Reset	Description
7:0	ExtTemp3MSB	r	00000000	MSB of External Temperature $T_{D3}$ . LSB=1°C

**Addr: 0x2F RegExtTemp3LSB**

Bits	Name	Mode	Reset	Description
7:3	Reserved	r	00000	
2:0	ExtTemp3LSB	r	000	LSB of External Temperature $T_{D3}$ . LSB=0.125°C

**ADVANCED COMMUNICATIONS & SENSING**
**DATASHEET**
**Addr: 0x30 RegControl**

Bits	Name	Mode	Reset	Description
7:5	Reserved	rw	000	Write to 000
4	ClockStretching	rw	1	0: No clock stretching 1: Enable clock stretching
3	TempOffsetMode	rw	0	0: Binary mode 1: Offset binary mode
2	Point3	rw	0	0: Disable 3-point track resistance cancellation 1: Enable 3-point track resistance cancellation
1	Algo	rw	0	0: Disable algorithmic track cancellation 1: Enable algorithmic track cancellation
0	Bit0	rw	1	This bit must be set to 1

**Addr: 0x31 RegStatus**

Bits	Name	Mode	Reset	Description
7:4	Reserved	w	0000	Write to 0000
3	ExtTemp3End	w <sup>1</sup>	0	1: External temperature 3 conversion complete
2	ExtTemp2End	w <sup>1</sup>	0	1: External temperature 2 conversion complete
1	ExtTemp1End	w <sup>1</sup>	0	1: External temperature 1 conversion complete
0	IntTempEnd	w <sup>1</sup>	0	1: Internal temperature conversion complete

1. write logic 1 to register bit to clear

## 8. Packaging Information

### 8.1. MLPD-W6-EP2 Package Outline Drawing

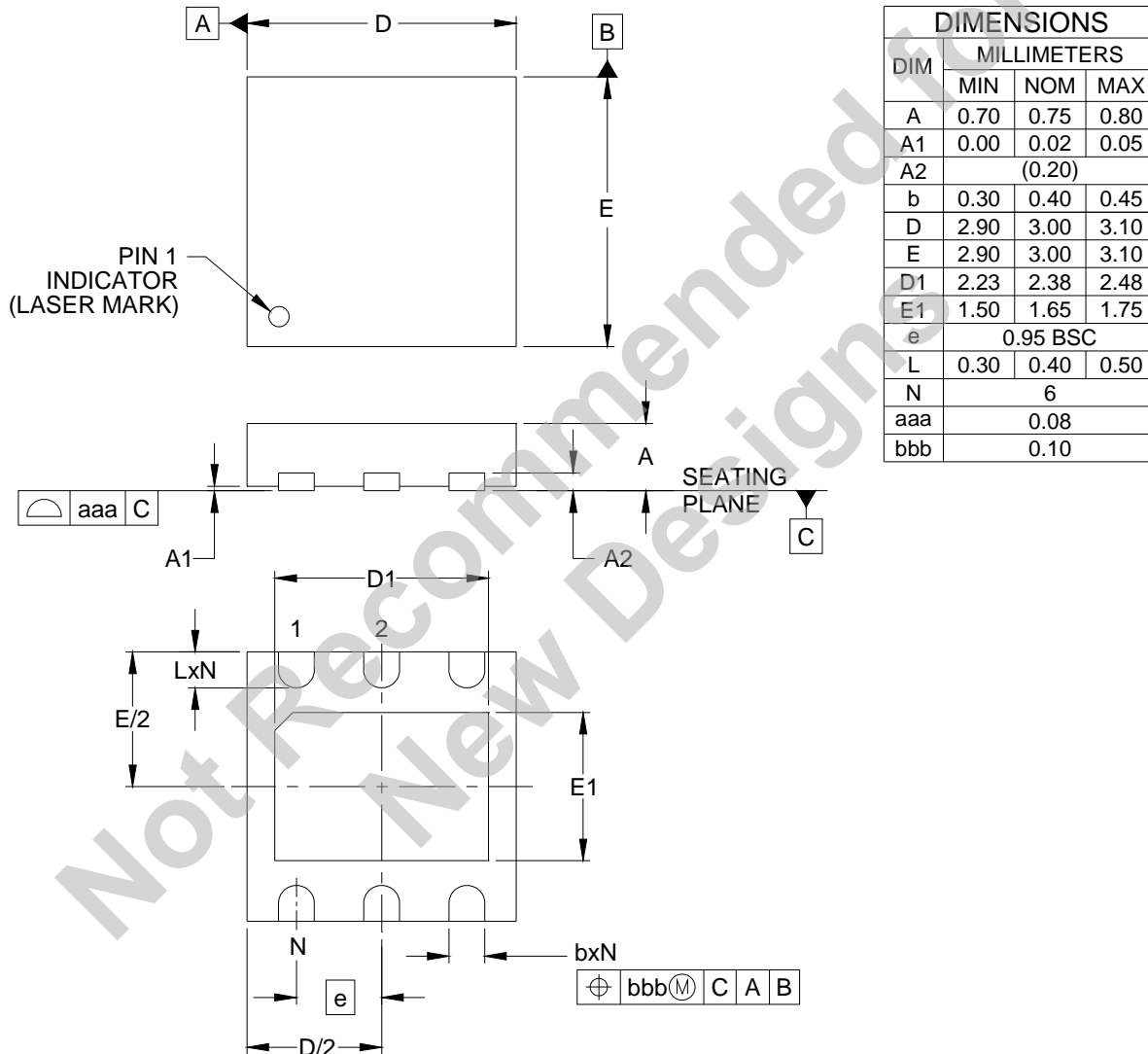
**NOTES:**

1. CONTROLLING DIMENSIONS ARE IN MILLIMETERS (ANGLES IN DEGREES).
2. COPLANARITY APPLIES TO THE EXPOSED PAD AS WELL AS TERMINALS.

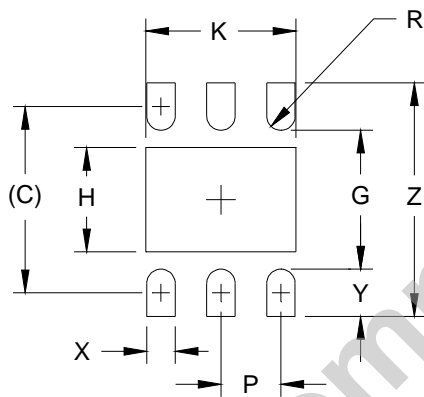
**8.2. MLPD-W6-EP2 Land Pattern Drawing**

DIMENSIONS	
DIM	MILLIMETERS
C	(2.95)
G	2.20
H	1.65
K	2.38
P	0.95
R	0.225
X	0.45
Y	0.75
Z	3.70

**NOTES:**

1. CONTROLLING DIMENSIONS ARE IN MILLIMETERS (ANGLES IN DEGREES).
2. THIS LAND PATTERN IS FOR REFERENCE PURPOSES ONLY. CONSULT YOUR MANUFACTURING GROUP TO ENSURE YOUR COMPANY'S MANUFACTURING GUIDELINES ARE MET.
3. THERMAL VIAS IN THE LAND PATTERN OF THE EXPOSED PAD SHALL BE CONNECTED TO A SYSTEM GROUND PLANE. FAILURE TO DO SO MAY COMPROMISE THE THERMAL AND/OR FUNCTIONAL PERFORMANCE OF THE DEVICE.

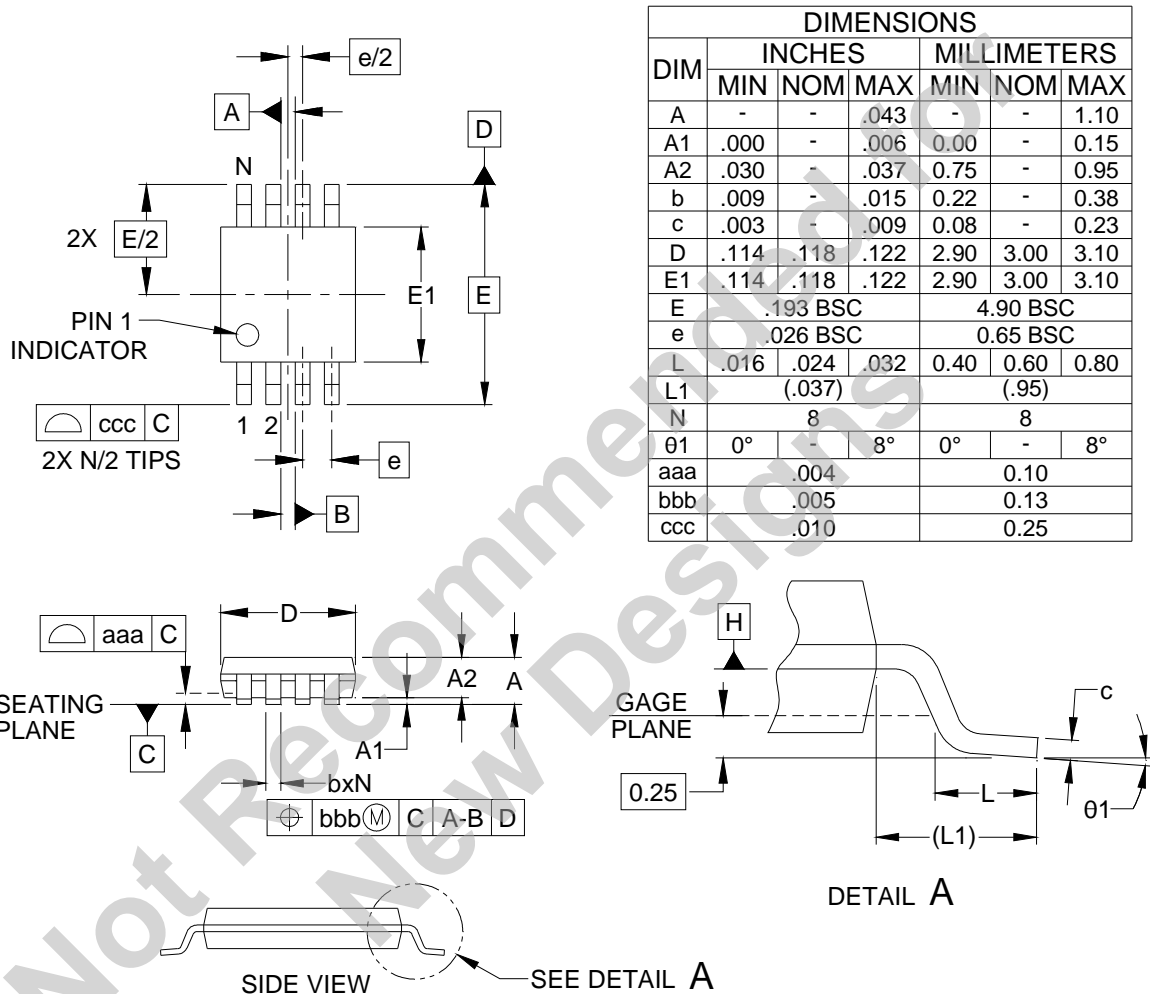
**8.3. Package Outline Drawing: MSOP-8**

**NOTES:**

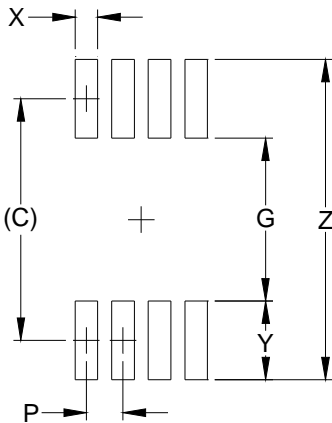
1. CONTROLLING DIMENSIONS ARE IN MILLIMETERS (ANGLES IN DEGREES).
2. DATUMS **-A-** AND **-B-** TO BE DETERMINED AT DATUM PLANE **-H-**
3. DIMENSIONS "E1" AND "D" DO NOT INCLUDE MOLD FLASH, PROTRUSIONS OR GATE BURRS.
4. REFERENCE JEDEC STD MO-187, VARIATION AA.

**8.4. Land Pattern Drawing: MSOP-8**

DIMENSIONS		
DIM	INCHES	MILLIMETERS
C	(.161)	(4.10)
G	.098	2.50
P	.026	0.65
X	.016	0.40
Y	.063	1.60
Z	.224	5.70

**NOTES:**

1. THIS LAND PATTERN IS FOR REFERENCE PURPOSES ONLY. CONSULT YOUR MANUFACTURING GROUP TO ENSURE YOUR COMPANY'S MANUFACTURING GUIDELINES ARE MET.



© Semtech 2011

All rights reserved. Reproduction in whole or in part is prohibited without the prior written consent of the copyright owner. The information presented in this document does not form part of any quotation or contract, is believed to be accurate and reliable and may be changed without notice. No liability will be accepted by the publisher for any consequence of its use. Publication thereof does not convey nor imply any license under patent or other industrial or intellectual property rights. Semtech assumes no responsibility or liability whatsoever for any failure or unexpected operation resulting from misuse, neglect improper installation, repair or improper handling or unusual physical or electrical stress including, but not limited to, exposure to parameters beyond the specified maximum ratings or operation outside the specified range.

SEMTECH PRODUCTS ARE NOT DESIGNED, INTENDED, AUTHORIZED OR WARRANTED TO BE SUITABLE FOR USE IN LIFE-SUPPORT APPLICATIONS, DEVICES OR SYSTEMS OR OTHER CRITICAL APPLICATIONS. INCLUSION OF SEMTECH PRODUCTS IN SUCH APPLICATIONS IS UNDERSTOOD TO BE UNDERTAKEN SOLELY AT THE CUSTOMER'S OWN RISK. Should a customer purchase or use Semtech products for any such unauthorized application, the customer shall indemnify and hold Semtech and its officers, employees, subsidiaries, affiliates, and distributors harmless against all claims, costs damages and attorney fees which could arise.

All referenced brands, product names, service names and trademarks are the property of their respective owners.

## Contact information

### Semtech Corporation Advanced Communications & Sensing Products

E-mail: [sales@semtech.com](mailto:sales@semtech.com) [casupport@semtech.com](mailto:casupport@semtech.com) Internet: <http://www.semtech.com>

<b>USA</b>	200 Flynn Road, Camarillo, CA 93012-8790. Tel: +1 805 498 2111 Fax: +1 805 498 3804
<b>FAR EAST</b>	12F, No. 89 Sec. 5, Nanking E. Road, Taipei, 105, TWN, R.O.C. Tel: +886 2 2748 3380 Fax: +886 2 2748 3390
<b>EUROPE</b>	Semtech Ltd., Units 2 & 3, Park Court, Premier Way, Abbey Park Industrial Estate, Romsey, Hampshire, SO51 9DN. Tel: +44 (0)1794 527 600 Fax: +44 (0)1794 527 601