

DESIGNED & DIMENSIONED
IN MILLIMETERS [INCHES]

QRM8-XXX-XX-X-RA-GP-XX

DO NOT
SCALE FROM
THIS PRINT

- OPTION**
 -K: POLYIMIDE FILM
 (NOT AVAILABLE FOR
 -026 & -078)
 (USE K-DOT-.276-.375-.005.
 SEE FIG. 2, SHT 4)
 -TR: TAPE & REEL
 (SEE NOTE 8)
- GUIDE POSTS**
 -GP
- RIGHT ANGLE**
 -RA
- PLATING SPECIFICATION**
 -S: 30µ" SELECTIVE GOLD IN CONTACT AREA
 MATTE TIN ON TAIL
 (USE T-1M52-XX-S & IM-T-1G35-XX-S)
 -L: 10µ" SELECTIVE GOLD IN CONTACT AREA
 MATTE TIN ON TAIL
 (USE T-1M52-XX-L & IM-T-1G35-XX-L)

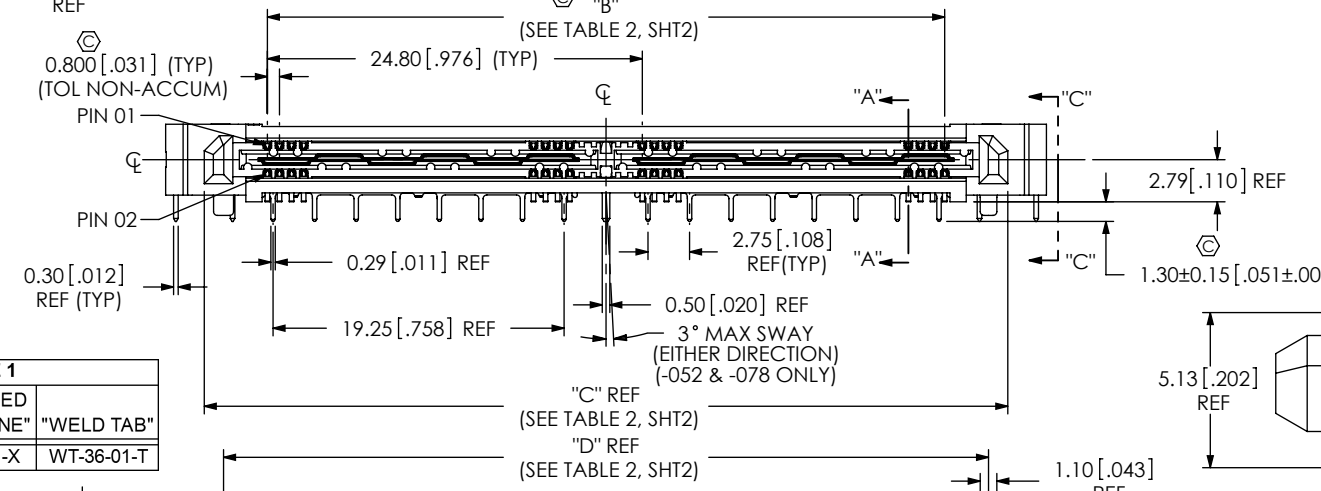
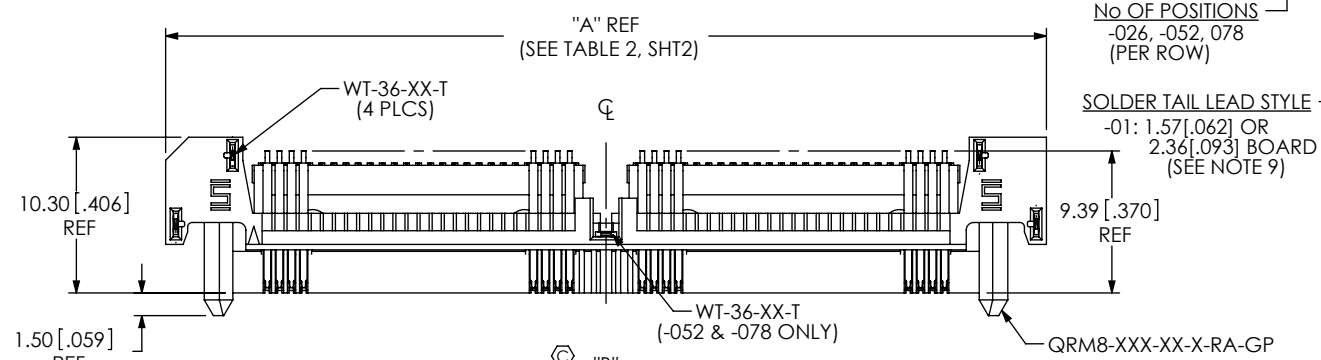
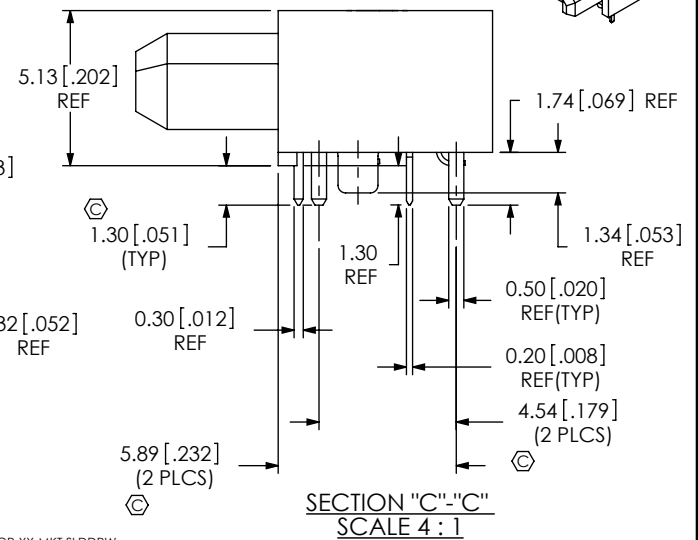
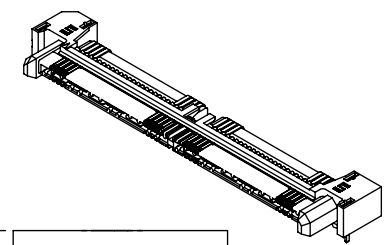

TABLE 1

LEAD STYLE	"OVER MOLDED GROUND PLANE"	"WELD TAB"
-01	IM-T-1G35-01-X	WT-36-01-T



- NOTES:
- ⊙ REPRESENTS A CRITICAL DIMENSION.
 - BURR ALLOWANCE: 0.038[.0015] MAX.
 - MINIMUM PUSHOUT FORCE: SIGNAL: 2.22N[.5 LB].
GROUND PLANE: 4.45N[1 LB].
 - MEASURE AT BEND TANGENCY.
 - MEASURE ON PINS ONLY, STANDOFFS NOT INCLUDED IN MEASUREMENT.
 - POST HEIGHT VARIATION BETWEEN ANY TWO PINS: 0.05[.002] MAXIMUM.
 - NOTE DELETED
 - PARTS TO BE PACKAGED IN TRAYS, UNLESS -TR OPTION IS SPECIFIED.
-078 POSITION IS NOT AVAILABLE IN TAPE AND REEL.
 - THE -01 SOLDER TAIL LEAD STYLE CAN BE USED FOR A 1.57[.062] OR A 2.36[.093] THICK PCB IF SAMTEC'S RECOMMENDED STENCIL APERTURE IS UTILIZED.
 - DIMENSIONS MUST BE MEASURED BOTH ENDS OF COMB OR CONNECTOR.
 - NOTE DELETED.
 - NOTE DELETED.
 - USE INSPECTION FIXTURE # AT-2321-801-XX TO CHECK THIS DIMENSION.
 - THIS SURFACE MUST BE PARALLEL TO WITHIN 1.5° OF -F-.
 - SHEAR BURR ALLOWANCE: .015 [.006] MAX ON THIS EDGE.

FIG 1
(QRM8-052-01-X-RA-GP SHOWN)
(SOME DETAIL REMOVED FOR CLARITY)

F:\DWG\MISC\WKTG\QRM8-XXX-XX-X-RA-GP-XX-MKT.SLDDRW

UNLESS OTHERWISE SPECIFIED, DIMENSIONS ARE IN MILLIMETERS [INCHES]. TOLERANCES ARE: DECIMALS ANGLES X.X: ±0.3 [.01] X.XX: ±0.13 [.005] X.XXX: ±0.050 [.0020]	PROPRIETARY NOTE THIS DOCUMENT CONTAINS CONFIDENTIAL AND PROPRIETARY INFORMATION AND ALL DESIGN, MANUFACTURING, REPRODUCTION, USE, PATENT RIGHTS AND SALES RIGHTS ARE EXPRESSLY RESERVED BY SAMTEC, INC. THIS DOCUMENT SHALL NOT BE DISCLOSED, IN WHOLE OR PART, TO ANY UNAUTHORIZED PERSON OR ENTITY NOR REPRODUCED, TRANSFERRED OR INCORPORATED IN ANY OTHER PROJECT IN ANY MANNER WITHOUT THE EXPRESS WRITTEN CONSENT OF SAMTEC, INC.	<p>520 PARK EAST BLVD, NEW ALBANY, IN 47150 PHONE: 812-944-6733 FAX: 812-948-5047 e-Mail info@SAMTEC.com code 55322</p>
MATERIAL: DO NOT SCALE DRAWING SHEET SCALE: 2:1 INSULATORS: LCP UL94V-0; COLOR: BLACK CONTACT: PHOS BRONZE GROUND PLANE: PHOS BRONZE	DESCRIPTION: 0.8mm Q-RATE RIGHT ANGLE TERMINAL ASSEMBLY DWG. NO. QRM8-XXX-XX-X-RA-GP-XX BY: R MUSSER 10/02/2008 SHEET 1 OF 6	

No OF POSITIONS	BOTTOM ROW STRAIGHTNESS	TOP ROW STRAIGHTNESS	COPLANARITY
-026, -052, -078	0.10 [0.004]	0.10 [0.004]	0.15 [0.006]

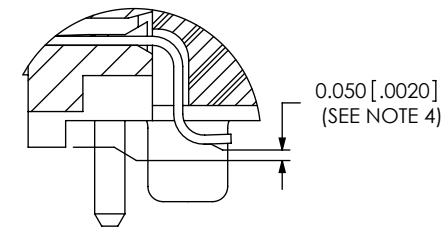
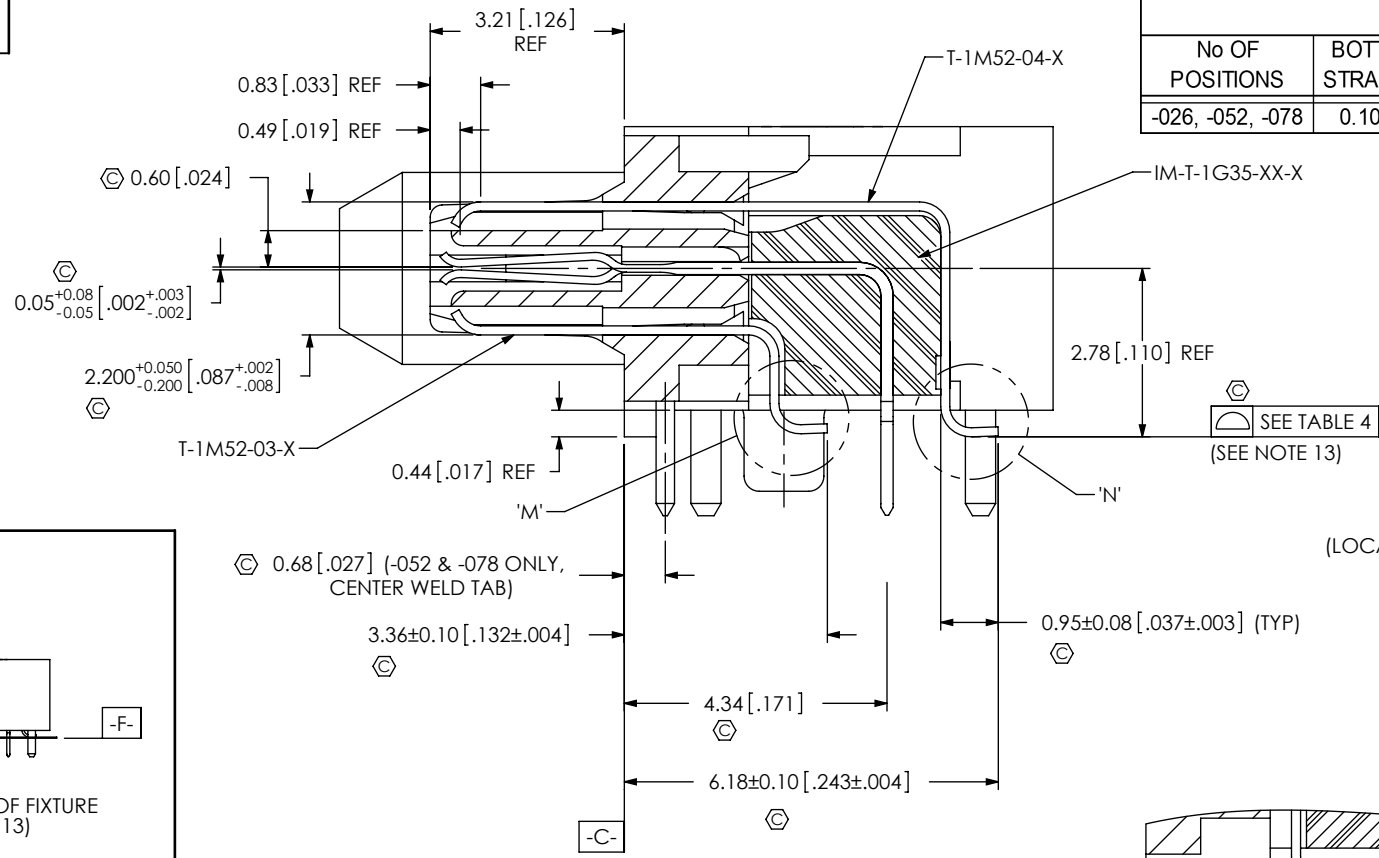

DETAIL 'M'
BOTTOM ROW TAIL
(LOCATE ASSY ON DATUM -C- FOR MEASUREMENT)

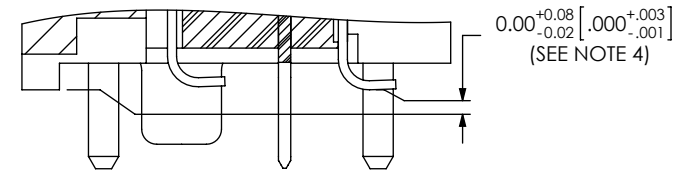

DETAIL 'N'
TOP ROW TAIL
(LOCATE ASSY ON DATUM -C- FOR MEASUREMENT)

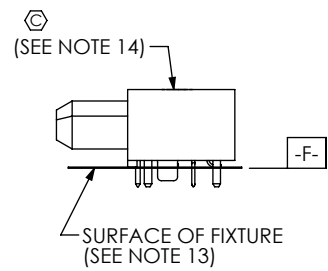

INSPECTION VIEW 3

SECTION "A"- "A"
SCALE 8 : 1

No OF POSITIONS	"A"	"B"	"C"	"D"	"E"	"F"
-026	33.46 [1.317]	20.00 [0.787]	28.35 [1.116]	25.80 [1.016]	32.11 [1.264]	24.61 [0.969]
-052	58.26 [2.294]	44.80 [1.764]	53.15 [2.093]	50.60 [1.992]	56.91 [2.240]	49.41 [1.945]
-078	83.06 [3.270]	69.60 [2.740]	77.95 [3.069]	75.40 [2.969]	81.71 [3.217]	74.21 [2.921]

PROPRIETARY NOTE
THIS DOCUMENT CONTAINS CONFIDENTIAL AND PROPRIETARY INFORMATION AND ALL DESIGN, MANUFACTURING, REPRODUCTION, USE, PATENT RIGHTS AND SALES RIGHTS ARE EXPRESSLY RESERVED BY SAMTEC, INC. THIS DOCUMENT SHALL NOT BE DISCLOSED, IN WHOLE OR PART, TO ANY UNAUTHORIZED PERSON OR ENTITY NOR REPRODUCED, TRANSFERRED OR INCORPORATED IN ANY OTHER PROJECT IN ANY MANNER WITHOUT THE EXPRESS WRITTEN CONSENT OF SAMTEC, INC.



520 PARK EAST BLVD, NEW ALBANY, IN 47150
PHONE: 812-944-6733 FAX: 812-948-5047
e-Mail info@SAMTEC.com code 55322

DO NOT SCALE DRAWING
SHEET SCALE: 2:1

DESCRIPTION:
0.8mm Q-RATE RIGHT ANGLE TERMINAL ASSEMBLY
DWG. NO.
QRM8-XXX-XX-X-RA-GP-XX
BY: R MUSSER 10/02/2008 SHEET 2 OF 6

REVISION Q

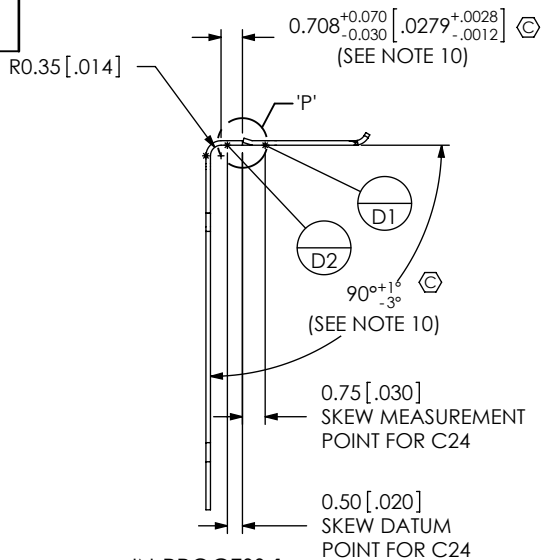

IN-PROCESS 1
(FORM 1 CONTACT T-1M52-03-X)
(RIGHT SIDE SHOWN)

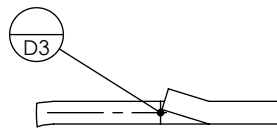

DETAIL 'P'
SCALE 20 : 1

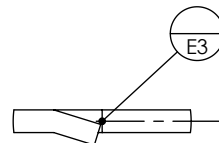

DETAIL 'Q'
SCALE 20 : 1

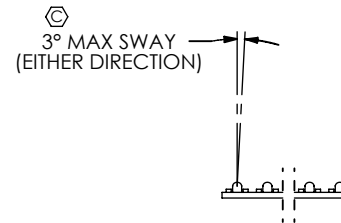

0.25±0.08 [.010±0.003]

T-1M52-XX-X IN-PROCESS VIEW

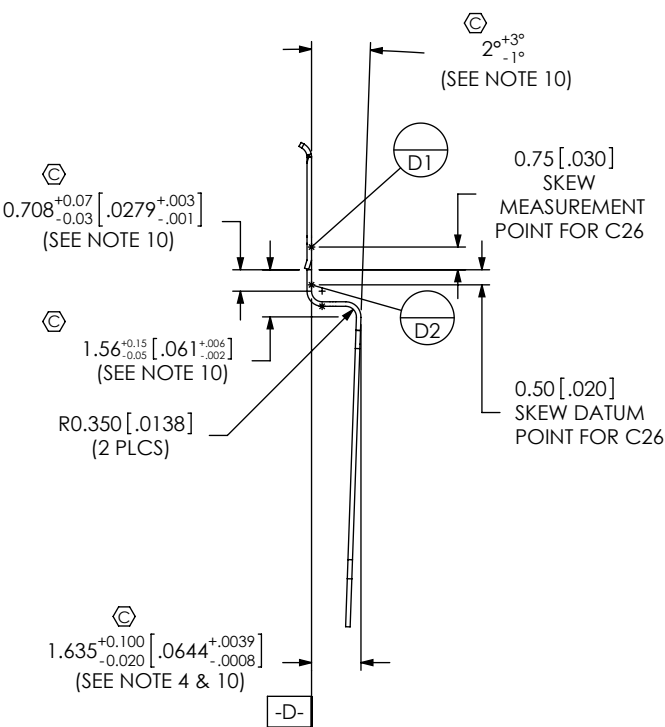
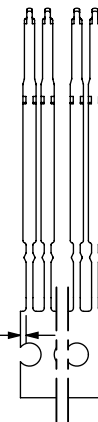

IN-PROCESS 2
(FORM 2 CONTACT T-1M52-03-X)
(RIGHT SIDE SHOWN)

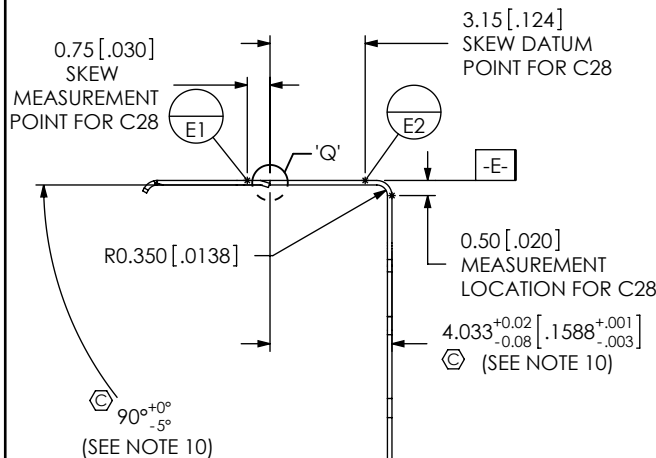

IN-PROCESS 6
(FORM 1 CONTACT T-1M52-04-X)
(LEFT SIDE SHOWN)

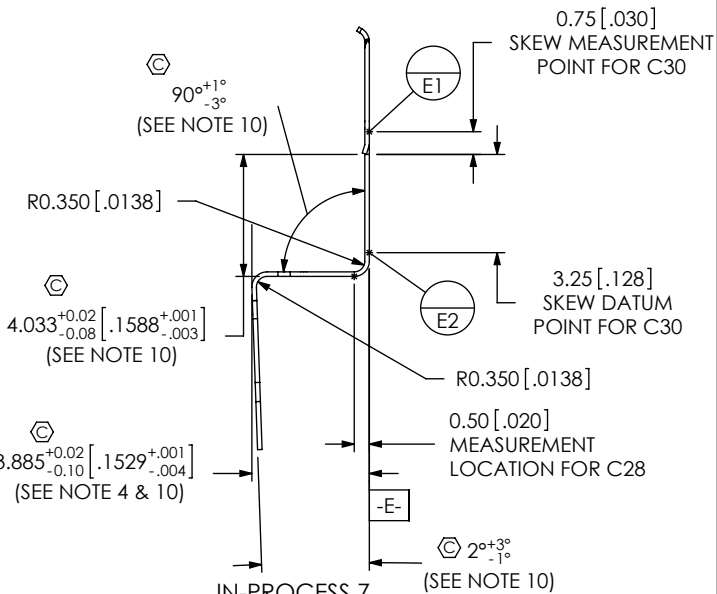

IN-PROCESS 7
(FORM 2 CONTACT T-1M52-04-X)
(LEFT SIDE SHOWN)

PROPRIETARY NOTE
THIS DOCUMENT CONTAINS CONFIDENTIAL AND PROPRIETARY INFORMATION AND ALL DESIGN, MANUFACTURING, REPRODUCTION, USE, PATENT RIGHTS AND SALES RIGHTS ARE EXPRESSLY RESERVED BY SAMTEC, INC. THIS DOCUMENT SHALL NOT BE DISCLOSED, IN WHOLE OR PART, TO ANY UNAUTHORIZED PERSON OR ENTITY NOR REPRODUCED, TRANSFERRED OR INCORPORATED IN ANY OTHER PROJECT IN ANY MANNER WITHOUT THE EXPRESS WRITTEN CONSENT OF SAMTEC, INC.



520 PARK EAST BLVD, NEW ALBANY, IN 47150
PHONE: 812-944-6733 FAX: 812-948-5047
e-Mail info@SAMTEC.com code 55322

DO NOT SCALE DRAWING

SHEET SCALE: 4:1

DESCRIPTION:
0.8mm Q-RATE RIGHT ANGLE TERMINAL ASSEMBLY

DWG. NO.
QRM8-XXX-XX-X-RA-GP-XX

BY: R MUSSER 10/02/2008 SHEET 3 OF 6

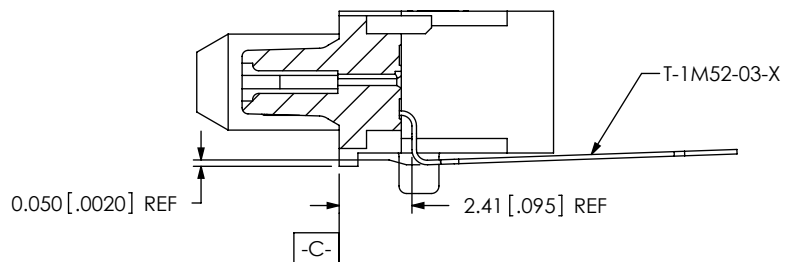

IN-PROCESS 3
(FILL BOTTOM ROW)
(SEE INSPECTION VIEW 1 FOR ASSEMBLY ORIENTATION AND CPC'S)

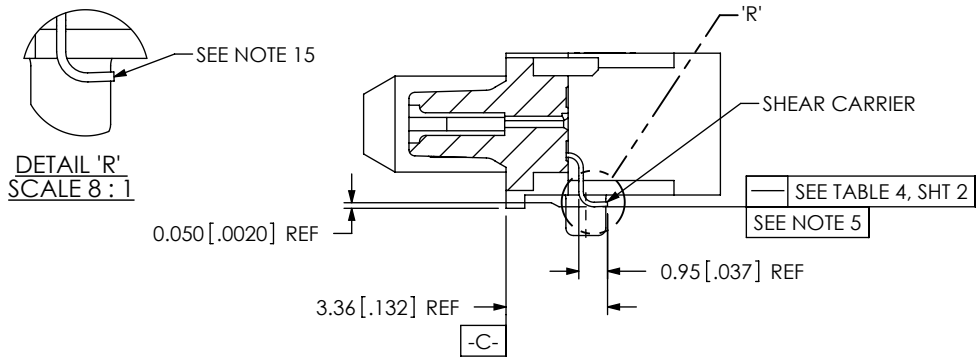

IN-PROCESS 4
(CUTOFF OF CARRIER)
(SEE INSPECTION VIEW 1 FOR ASSEMBLY ORIENTATION AND CPC'S)

INSPECTION VIEW 1

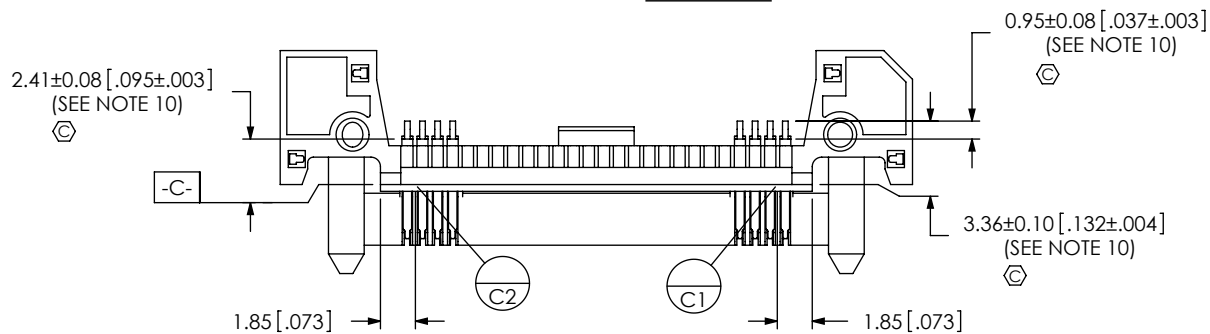
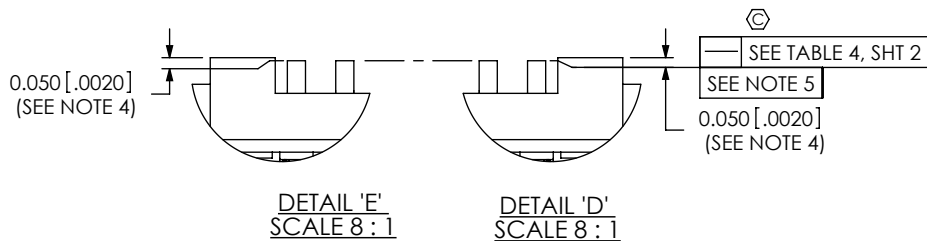
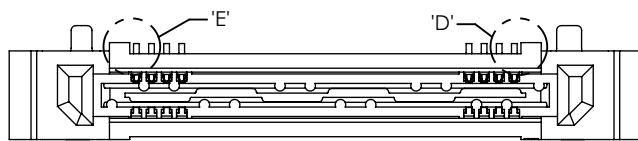

INSPECTION FOR IN-PROCESS 3 & 4
(CARRIER NOT SHOWN FOR IN PROCESS 3 INSPECTIONS)

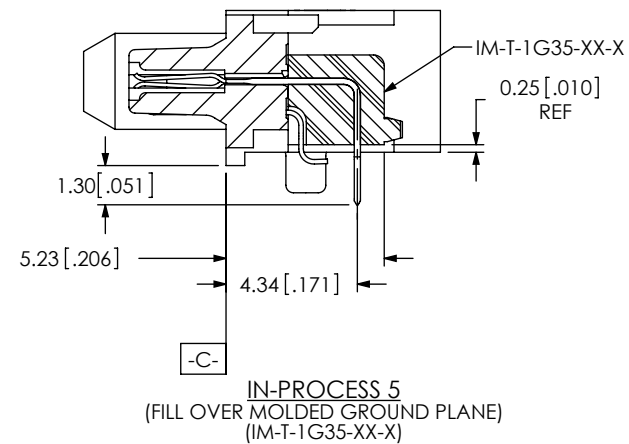

IN-PROCESS 5
(FILL OVER MOLDED GROUND PLANE)
(IM-T-1G35-XX-X)

PROPRIETARY NOTE
THIS DOCUMENT CONTAINS CONFIDENTIAL AND PROPRIETARY INFORMATION AND ALL DESIGN, MANUFACTURING, REPRODUCTION, USE, PATENT RIGHTS AND SALES RIGHTS ARE EXPRESSLY RESERVED BY SAMTEC, INC. THIS DOCUMENT SHALL NOT BE DISCLOSED, IN WHOLE OR PART, TO ANY UNAUTHORIZED PERSON OR ENTITY NOR REPRODUCED, TRANSFERRED OR INCORPORATED IN ANY OTHER PROJECT IN ANY MANNER WITHOUT THE EXPRESS WRITTEN CONSENT OF SAMTEC, INC.



520 PARK EAST BLVD, NEW ALBANY, IN 47150
PHONE: 812-944-6733 FAX: 812-948-5047
e-Mail info@SAMTEC.com code 55322

DO NOT SCALE DRAWING

SHEET SCALE: 4:1

DESCRIPTION:
0.8mm Q-RATE RIGHT ANGLE TERMINAL ASSEMBLY

DWG. NO.
QRM8-XXX-XX-X-RA-GP-XX

BY: R MUSSER 10/02/2008 SHEET 4 OF 6

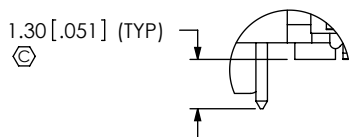
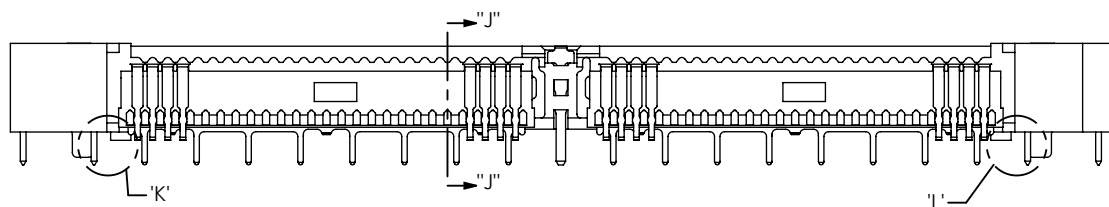

DETAIL 'K'
SCALE 5:1

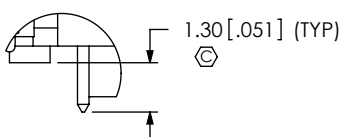

DETAIL 'L'
SCALE 5:1

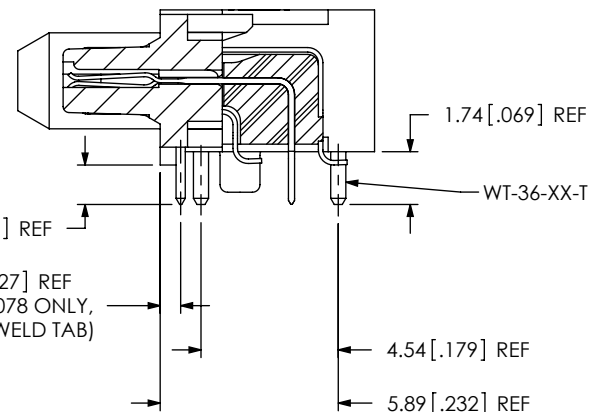

SECTION "J"-"J"

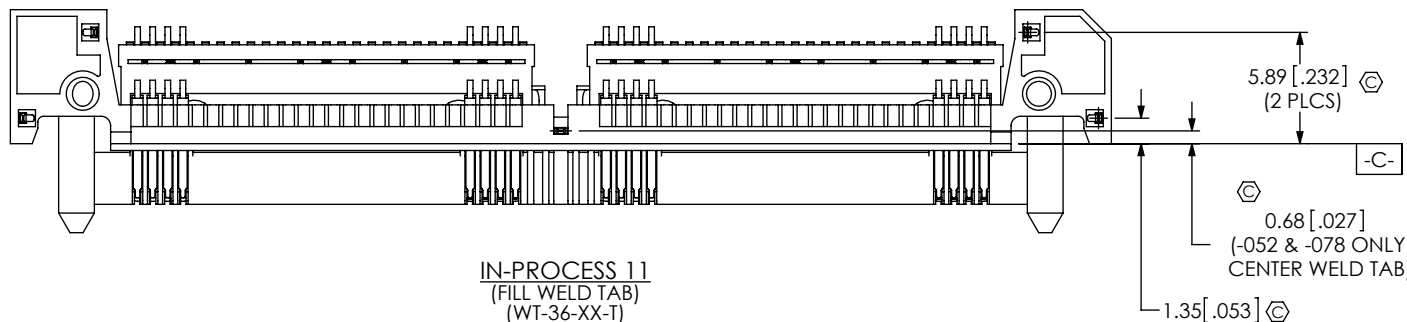

IN-PROCESS 11
(FILL WELD TAB)
(WT-36-XX-T)

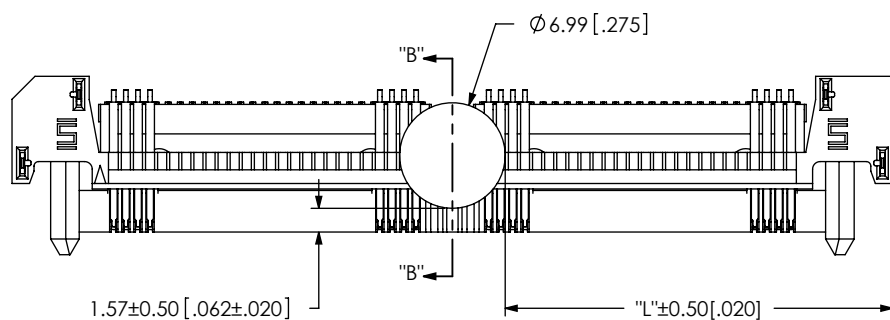
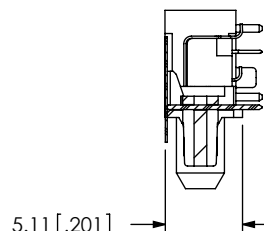

FIG 2
-K OPTION
(USE K-DOT-.276-.375-.005)
(QRM8-052-01-X-RA-GP-K SHOWN)
(SOME DETAIL REMOVED FOR CLARITY)

SECTION "B"-"B"
SCALE 2:1



No OF POSITIONS	"L"
-026	13.24 [0.521]
-052	25.64 [1.009]
-078	38.04 [1.498]

PROPRIETARY NOTE
THIS DOCUMENT CONTAINS CONFIDENTIAL AND PROPRIETARY INFORMATION AND ALL DESIGN, MANUFACTURING, REPRODUCTION, USE, PATENT RIGHTS AND SALES RIGHTS ARE EXPRESSLY RESERVED BY SAMTEC, INC. THIS DOCUMENT SHALL NOT BE DISCLOSED, IN WHOLE OR PART, TO ANY UNAUTHORIZED PERSON OR ENTITY NOR REPRODUCED, TRANSFERRED OR INCORPORATED IN ANY OTHER PROJECT IN ANY MANNER WITHOUT THE EXPRESS WRITTEN CONSENT OF SAMTEC, INC.



520 PARK EAST BLVD, NEW ALBANY, IN 47150
PHONE: 812-944-6733 FAX: 812-948-5047
e-Mail info@SAMTEC.com code 55322

DO NOT SCALE DRAWING

SHEET SCALE: 4:1

DESCRIPTION:
0.8mm Q-RATE RIGHT ANGLE TERMINAL ASSEMBLY

DWG. NO.
QRM8-XXX-XX-X-RA-GP-XX

BY: R MUSSER 10/02/2008 SHEET 6 OF 6