

DATE

REVISIONS

REV

DRAWING NUMBER
SSL-LX3054ID-TR

REV

ELECTRO-OPTICAL CHARACTERISTICS $T_A=25^\circ\text{C}$ $I_f=20\text{mA}$

PARAMETER	MIN	TYP	MAX	UNITS	TEST COND
PEAK WAVELENGTH		635 (RED)		nm	
FORWARD VOLTAGE		2.0	2.8	V_f	
REVERSE VOLTAGE	5.0			V_r	$I_r=100\mu\text{A}$
AXIAL INTENSITY		10		mcd	$I_f=20\text{mA}$
VIEWING ANGLE		60		2x theta	
EMITTED COLOR		RED			
EPOXY LENS FINISH		RED DIFFUSED			

LIMITS OF SAFE OPERATION AT 25°C

PARAMETER	MAX	UNITS
PEAK FORWARD CURRENT*	150	mA
STEADY CURRENT	30	mA
POWER DISSIPATION	105	mW
DERATE FROM 25°C	-1.4	$\text{mW}/^\circ\text{C}$
OPERATING, STORAGE TEMP	-40 TO +85	$^\circ\text{C}$
LEAD SOLDERING TEMP	+260	$^\circ\text{C}$
2.0mm FROM BODY	3 SEC. MAX	

* $t < 10\mu\text{s}$ RELIABILITY NOTE

OUR MANY YEARS OF EXPERIENCE DATA ACCUMULATION INDICATE THAT SOLDER HEAT IS A MAJOR CAUSE OF EARLY AND FUTURE FAILURE. PLEASE PAY ATTENTION TO YOUR SOLDERING PROCESS.

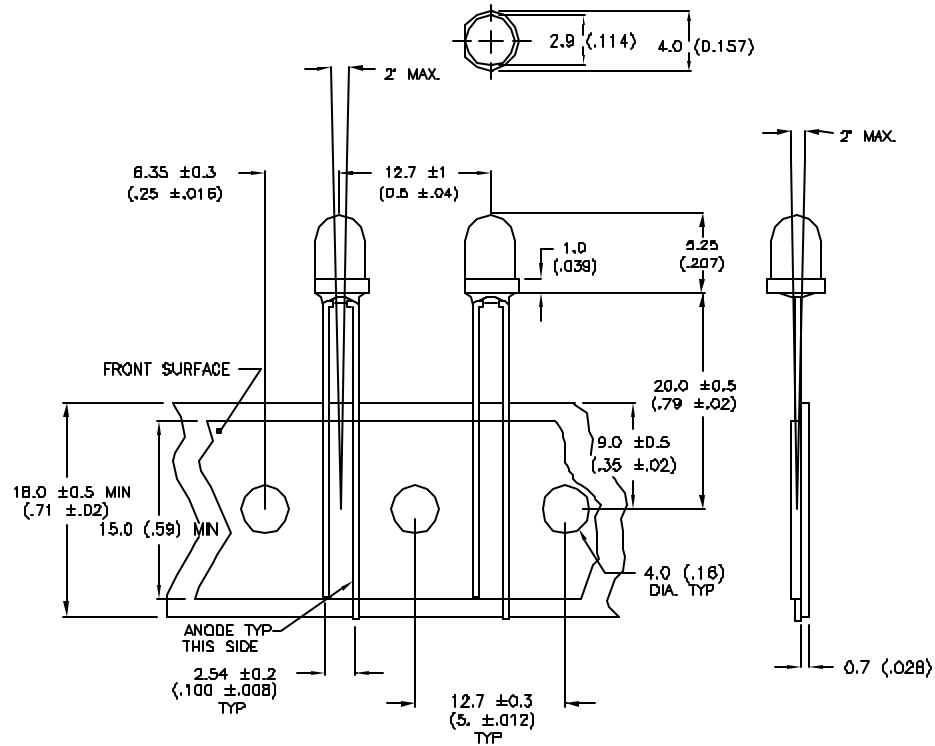
NOTE

1. 1.5K PER REEL

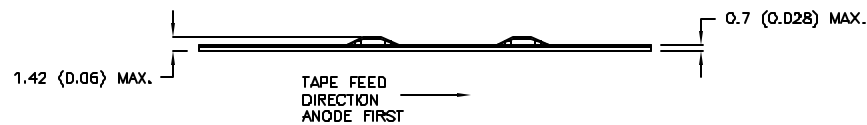
TOLERANCE: ± 0.2 ($\pm .008$)

MS/SS

LUMEX
OPTO COMPONENTS INC.

292 E. HELLEN ROAD
PALATINE, ILLINOIS 60067
(708) 359-2790

CONFIDENTIAL INFORMATION

THE INFORMATION CONTAINED IN THIS DOCUMENT IS THE PROPERTY OF LUMEX OPTO/COMPONENTS, INC. EXCEPT AS SPECIFICALLY AUTHORIZED IN WRITING BY LUMEX OPTO/COMPONENTS, INC., THE HOLDER OF THIS DOCUMENT SHALL KEEP ALL INFORMATION CONTAINED HEREIN CONFIDENTIAL AND SHALL PROTECT SAME IN WHOLE OR IN PART FROM DISCLOSURE AND DISSEMINATION TO ALL THIRD PARTIES.

DATE: 8-19-96	DWN:	CHK'D:	APPD:
SCALE: N/A			

T-3 (T-1) LED, RED DIFFUSED
TAPE AND REEL

PAGE 1 OF 1

DRAWING NUMBER
SSL-LX3054ID-TR

REV