

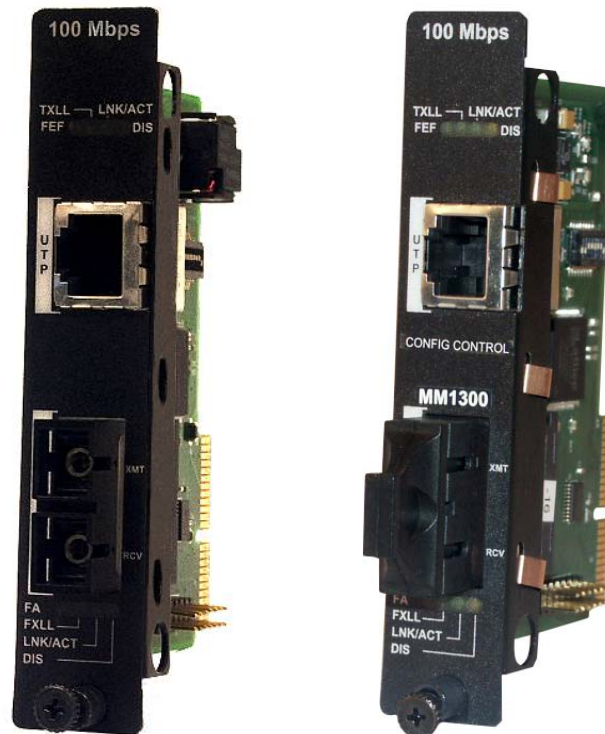

iMcV-LIM

Operation Manual



FCC Radio Frequency Interference Statement

This equipment has been tested and found to comply with the limits for a Class B computing device, pursuant to Part 15 of the FCC Rules. These limits are designed to provide reasonable protection against harmful interference when the equipment is operated in a commercial environment. This equipment generates, uses and can radiate radio frequency energy and, if not installed and used in accordance with the instruction manual, may cause harmful interference to radio communications. Operation of this equipment in a residential area is likely to cause harmful interference in which the user will be required to correct the interference at his own expense.

Any changes or modifications not expressly approved by the manufacturer could void the user's authority to operate the equipment.

The use of non-shielded I/O cables may not guarantee compliance with FCC RFI limits. This digital apparatus does not exceed the Class B limits for radio noise emission from digital apparatus set out in the Radio Interference Regulation of the Canadian Department of Communications.

Le présent appareil numérique n'émet pas de bruits radioélectriques dépassant les limites applicables aux appareils numériques de classe B prescrites dans le Règlement sur le brouillage radioélectrique publié par le ministère des Communications du Canada.

Warranty

IMC Networks warrants to the original end-user purchaser that this product, EXCLUSIVE OF SOFTWARE, shall be free from defects in materials and workmanship under normal and proper use in accordance with IMC Networks' instructions and directions for a period of six (6) years after the original date of purchase. This warranty is subject to the limitations set forth below.

At its option, IMC Networks will repair or replace at no charge the product which proves to be defective within such warranty period. This limited warranty shall not apply if the IMC Networks product has been damaged by unreasonable use, accident, negligence, service or modification by anyone other than an authorized IMC Networks Service Technician or by any other causes unrelated to defective materials or workmanship. Any replaced or repaired products or parts carry a ninety (90) day warranty or the remainder of the initial warranty period, whichever is longer.

To receive in-warranty service, the defective product must be received at IMC Networks no later than the end of the warranty period. The product must be accompanied by proof of purchase, satisfactory to IMC Networks, denoting product serial number and purchase date, a written description of the defect and a Return Merchandise Authorization (RMA) number issued by IMC Networks. No products will be accepted by IMC Networks which do not have an RMA number. For an RMA number, contact IMC Networks at PHONE: (800) 624-1070 (in the U.S and Canada) or (949) 465-3000 or FAX: (949) 465-3020. The end-user shall return the defective product to IMC Networks, freight, customs and handling charges prepaid. End-user agrees to accept all liability for loss of or damages to the returned product during shipment. IMC Networks shall repair or replace the returned product, at its option, and return the repaired or new product to the end-user, freight prepaid, via method to be determined by IMC Networks. IMC Networks shall not be liable for any costs of procurement of substitute goods, loss of profits, or any incidental, consequential, and/or special damages of any kind resulting from a breach of any applicable express or implied warranty, breach of any obligation arising from breach of warranty, or otherwise with respect to the manufacture and sale of any IMC Networks product, whether or not IMC Networks has been advised of the possibility of such loss or damage.

EXCEPT FOR THE EXPRESS WARRANTY SET FORTH ABOVE, IMC NETWORKS MAKES NO OTHER WARRANTIES, WHETHER EXPRESS OR IMPLIED, WITH RESPECT TO THIS IMC NETWORKS PRODUCT, INCLUDING WITHOUT LIMITATION ANY SOFTWARE ASSOCIATED OR INCLUDED. IMC NETWORKS SHALL DISREGARD AND NOT BE BOUND BY ANY REPRESENTATIONS OR WARRANTIES MADE BY ANY OTHER PERSON, INCLUDING EMPLOYEES, DISTRIBUTORS, RESELLERS OR DEALERS OF IMC NETWORKS, WHICH ARE

INCONSISTENT WITH THE WARRANTY SET FORTH ABOVE. ALL IMPLIED WARRANTIES INCLUDING THOSE OF MERCHANTABILITY AND FITNESS FOR A PARTICULAR PURPOSE ARE HEREBY LIMITED TO THE DURATION OF THE EXPRESS WARRANTY STATED ABOVE.

Every reasonable effort has been made to ensure that IMC Networks product manuals and promotional materials accurately describe IMC Networks product specifications and capabilities at the time of publication. However, because of ongoing improvements and updating of IMC Networks products, IMC Networks cannot guarantee the accuracy of printed materials after the date of publication and disclaims liability for changes, errors or omissions.

Table of Contents

FCC Radio Frequency Interference Statement	ii
Warranty.....	ii
About the iMcV-LIM	1
Configuration Instructions	1
Installing an iMcV-Modules	1
iMcV-LIM and Configuration Control	2
FX LinkLoss, TX LinkLoss, Link Fault Pass-Through, Far End Fault and FiberAlert.	6
Link Fault Pass-Through (LFPT).....	7
FiberAlert and Far End Fault.....	8
Auto Negotiation on iMcV-LIM	10
LED Operation.....	11
Installation Troubleshooting	12
Specifications	13
IMC Networks Technical Support.....	13
Fiber Optic Cleaning Guidelines.....	14
Electrostatic Discharge Precautions.....	15
Certifications.....	16

About the iMcV-LIM

The iMcV-LIM is a Fast Ethernet module which provides a single conversion between 100Base-TX twisted pair and 100Base-FX/SX single-mode or multi-mode fiber. Each iMcV-LIM includes one RJ-45 connector and one pair of ST or SC fiber optic connectors, and/or an SFP port, which can support any fiber type. Models with Configuration Control are identified by a label on the faceplate of the module.

Also available in a single-strand fiber version, iMcV-LIM TX/SSFx and iMcV-LIM TX/SFP with Configuration Control allow two wavelengths to share one fiber strand — Full-Duplex data travels on different wavelengths, for example (1310 nm and 1550 nm) — doubling the capacity of fiber.

The iMcV-LIM is SNMP-manageable and can be installed into the modular, SNMP-manageable iMediaChassis, as well as the MediaChassis series, which are unmanaged.

Configuration Instructions

The iMcV-LIM has user-configurable features (e.g., FiberAlert (FA), TX LinkLoss (TXLL), FX LinkLoss (FXLL), Link Fault Pass-Through (LFPT) and Far End Fault (FEF)). Refer to the iMcV-Module DIP Switch configuration table for information on available features. Instructions for configuring both managed (via an SNMP-compatible management application like iView²) and unmanaged modules follow.

Installing an iMcV-Modules

The iMcV-Modules install in IMC Networks' SNMP manageable iMediaChassis series or in any MediaChassis.

NOTE
All modules are hot-swappable.

To install an iMcV-Module:

1. Remove the blank bracket covering the slot where the module is to be installed by removing the screws on the outside edges of the bracket.
2. Slide the iMcV-Modules into the chassis, via the cardguides, until the module is seated securely in the connector.
3. Secure the module to the chassis by tightening the captive screw.
4. Save any "blanks" removed during installation for future use if the configuration requirements change.

Managed Modules

To manage one or more iMcV-LIM(s), an SNMP agent must be present in the chassis. To configure Managed Modules, install the module first, and then configure using the management software.

Fiber type, serial number and date code are now loaded into the NVRAM during manufacturing. This is viewed only via iView² software, within the modules details.

Requirements:

- SNMP Firmware version C2
- iView² 1.8.6 or higher

NOTE
For iMcV-LIM modules without Configuration Control, management software overrides any hardware settings (e.g., jumper, switch, etc.); a module must be configured so that it will be managed via the software.

iMcV-LIM and Configuration Control

The iMcV-LIM with SFP offers Configuration Control; a label on the front faceplate identifies the unit as such. Configuration Control has been implemented to assist the end user by retaining the latest configuration regardless of how that configuration was implemented (via DIP Switch settings or SNMP).

Historically, SNMP would override DIP Switch settings. If changes are made via DIP Switch settings, then hardware settings determine the configuration of the board. If changes are made to the module via iView², the SNMP settings determine the configuration of the board.

Utilizing Configuration Control, the end user has three conditions under which the configuration of the iMcV-Module may be impacted:

- Installing an iMcV-LIM into a chassis already loaded with iMcV-Modules or replacing an iMcV-LIM
 - The iMcV-Module will transfer its saved configurations. The iMcV-LIM will not override the module's configuration.
- Replacing the same type of iMcV-Module
 - If the DIP Switch settings are the same as the settings on the removed iMcV-Module, the iMcV-LIM determines the configuration settings.
 - If the DIP Switch settings are different, then the configuration of the module is determined by the DIP Switch settings. (The settings are forwarded to the iMcV-LIM and the value is saved.)
- Installing a new model of iMcV-Module

- If another type of module is installed into the same slot in a chassis, the iMcV-LIM clears the memory of the previous configuration for that slot; the settings of a new module are adopted and stored in the iMcV-LIM

The SNMP Write Lock switch does not impact any iMcV-Module or iMcV-Module with Configuration Control. Removing and installing a new SNMP Management Module will no longer impact these modules either. However, if there is a mixture of iMcV-Modules with and without Configuration Control, the Write Lock Switch and a new SNMP Management Module must be taken into consideration.

If the command cleandb is applied to an SNMP Management Module, all the settings for the modules will be removed, but the Configuration Control modules will still be based on the last change made, while those without Configuration Control will be set to their default settings.

NOTE
If the end user has a mixture of standard iMcV-Modules as well as Configuration Control iMcV-Modules, it is important to understand how SNMP and DIP Switches will impact the cards depending on their capability. Standard iMcV-Modules cannot be upgraded to Configuration Control capability, so it is strongly recommended to set the DIP Switches on the modules and then configure them via software to match the same settings.

Unmanaged Modules

Before installing, configure the iMcV-LIM modules for desired features. The table below indicates the available features and settings for the iMcV-LIM modules.

After configuring the DIP Switches for the desired settings, install the module and connect the appropriate cables (refer to Installing an iMcV-LIM section for more information).

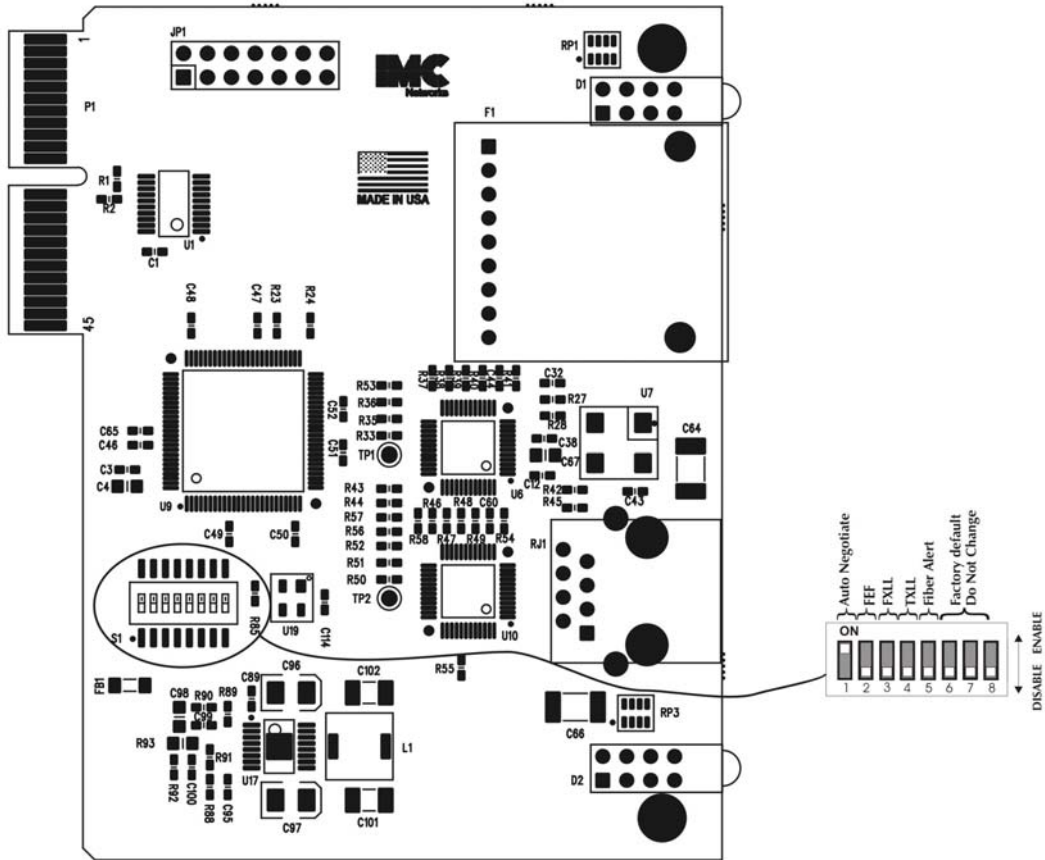

iMcV-LIM

DIP Switch on S1	Feature	Default Setting
1	Auto Negotiation (AN)	ON
2	Far End Fault (FEF)	OFF
3	FX LinkLoss (FXLL)	OFF
4	TX LinkLoss (TXLL)	OFF
5	FiberAlert (FA)	OFF
6	Factory Default	OFF
7	Factory Default	OFF
8	Factory Default	OFF

BEST PRACTICES

When possible, it is always a good idea to configure DIP Switches to match software settings.

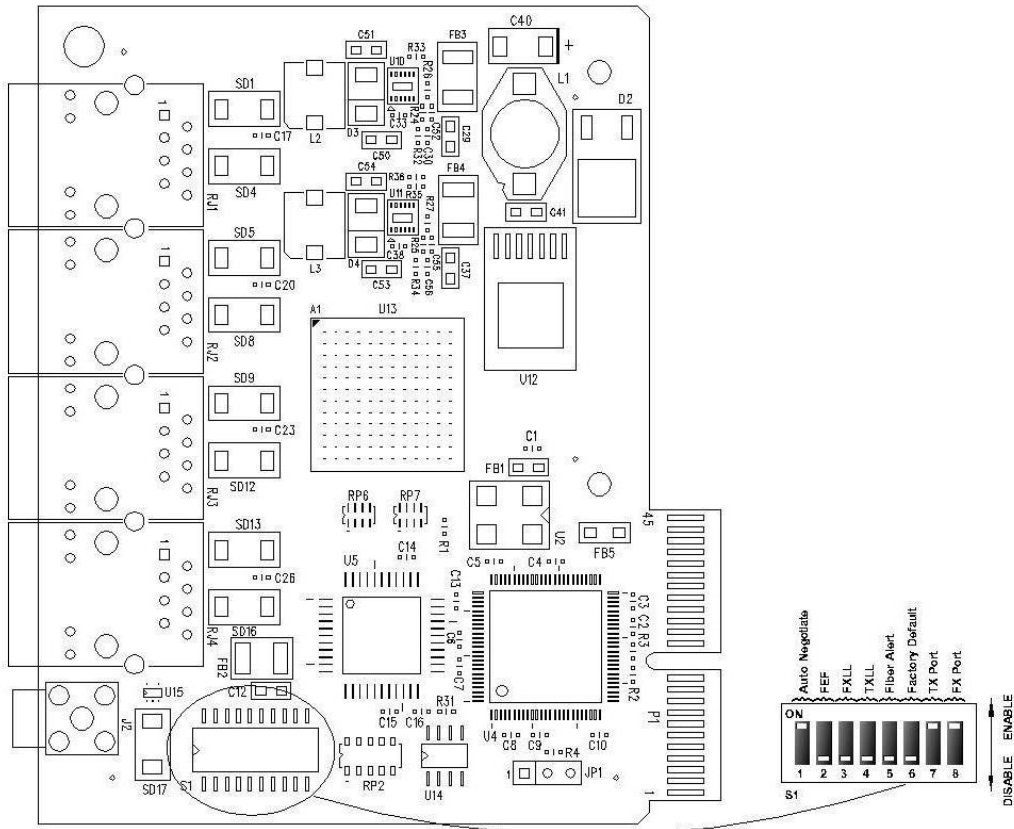

iMcV-LIM with SFP and Configuration Control

DIP Switch on S1	Feature	Default Setting
1	Auto Negotiation (AN)	ON
2	Far End Fault (FEF)	OFF
3	FX LinkLoss (FXLL)	OFF
4	TX LinkLoss (TXLL)	OFF
5	FiberAlert (FA)	OFF
6	Factory Default	OFF
7	Enable TX port	ON
8	Enable FX port	ON

FX LinkLoss, TX LinkLoss, Link Fault Pass-Through, Far End Fault and FiberAlert

iMcV-LIM modules include the troubleshooting features FiberAlert, TXLL, FXLL, FEF and LFPT that help locate *silent failures* on a network. Before attempting to install the module(s), understand how these features work and react to a specific network configuration.

Link Integrity

During normal operation, link integrity pulses are transmitted by all point-to-point Ethernet devices. When an IMC Networks media converter receives valid link pulses, it knows that the device to which it is connected is up and sending pulses, and that the copper or fiber cable coming from that device is intact. The appropriate “LNK” (link) LED is lit to indicate this.

The IMC Networks media converter also sends out link pulses from its copper and fiber transmitters, but normally has no way of knowing whether the cable to the other device is intact and the link pulses are reaching the other end. The combination of FiberAlert and LinkLoss allows this information to be obtained, even when physical access to a remote device (and its link integrity LED) is not available.

FX LinkLoss (FXLL)

FX LinkLoss is a troubleshooting feature. When enabled, if a fault occurs on the fiber segment of a conversation, FX LinkLoss detects the fault and passes this information to the twisted pair segment. If a media converter is not receiving a fiber link, FX LinkLoss disables the transmitter on the media converter’s twisted pair port. This results in a loss of link on the device connected to the twisted pair port, and the TXLL LED will blink.

TX LinkLoss (TXLL)

TX LinkLoss is a troubleshooting feature. When enabled, if a fault occurs on the twisted pair segment of a conversation, TX LinkLoss detects the fault and passes this information to the fiber segment. If a media converter is not receiving a twisted pair link, TX LinkLoss disables the transmitter on the media converter's fiber port. This results in a loss of the link on the device connected to the fiber port, and the FXLL LED will blink.

Link Fault Pass-Through (LFPT)

Link Fault Pass-Through (LFPT) is a troubleshooting feature that combines TX and FX LinkLoss from both the local and remote iMcV-LIM modules. LFPT is enabled by turning on both FX and TX LinkLoss on both modules. This feature allows either end of the conversion to detect a link fault occurring at the other end of the media conversion chain.

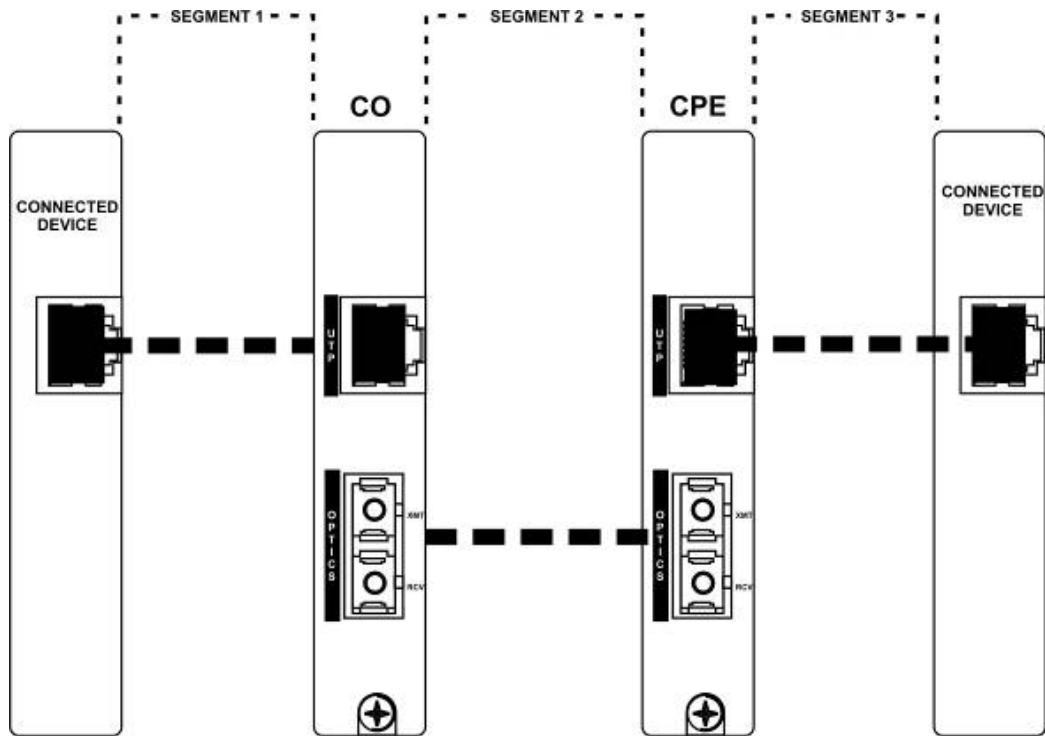

Regardless if there is a break in segment 1, 2 or 3, the link will drop on the switches at both ends. The link fault is passed through the media conversion and is observed at each end. It acts just like it would if the devices were directly connected.

FiberAlert and Far End Fault

Modules ship from the factory with troubleshooting features disabled. Refer to the help file to enable/disable this feature.

FiberAlert (FA)

FiberAlert minimizes the problems associated with the loss of one strand of fiber. If a strand is unavailable, the IMC Networks device at the receiver end notes the loss of link. The device will then stop transmitting data and the link signal until a signal or link pulse is received. The result is that the link LED on BOTH sides of the fiber connection will go out indicating a fault somewhere in the fiber loop. Using FiberAlert, a local site administrator is notified of a fault and can quickly determine where a cable fault is located.

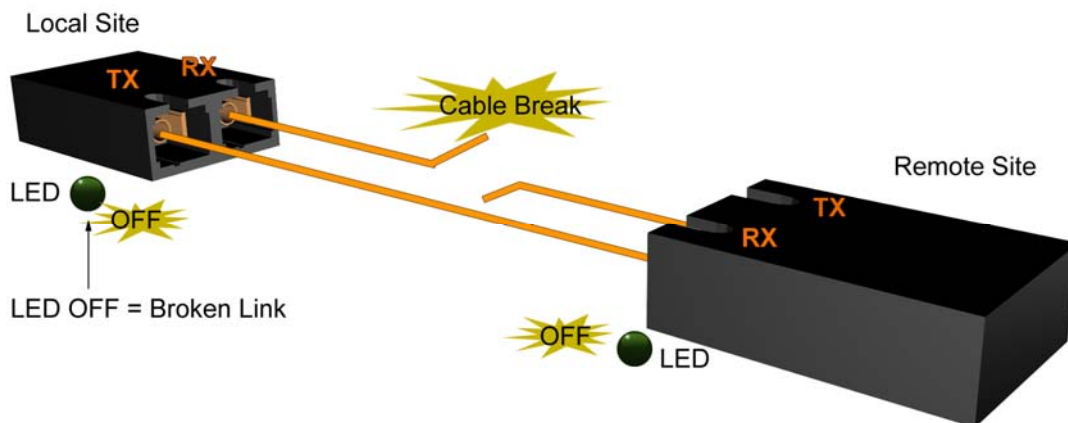

WARNING

Enable FiberAlert at the remote side of a media conversion only. Enabling it on both sides would keep both transmitters disabled indefinitely.

By default FA is disabled. When enabled if, a fault occurs on the fiber line, affecting data in one direction, FA stops sending signal in the opposite direction. FXLL will act on this lack of signal, propagating the loss of like to the copper port when FXLL is enabled.

Far End Fault

By default, FEF is disabled. When enabled, and a fault occurs on the fiber line, affecting data in one direction, an FEF signal will be sent in the opposite direction, indicating the fault. FXLL will act on this signal propagating the loss of link to the copper port when FXLL is enabled.

FEF versus FA

FEF is preferred when the devices at both ends of the fiber can interpret the FEF signal. This allows FEF to be turned on at both ends, which will engage the FEF regardless of which direction the fault occurs. (Please refer to diagram on previous page) For example if a fault should occur on segment 2 in the direction of segment 1 to 3, FEF would be engaged on the iMcV-LIM between segment 2 and 3. This would then send a signal back to the iMcV-LIM between segment 1 and 2. If the iMcV-LIM between segment 1 and 2 is in a managed chassis, the chassis would send a trap that the port is down. Alternatively, if the iMcV-LIM is not in a managed chassis, FXLL could be engaged to propagate the fault onto the copper port; this would cause segment 1 to show no link on both ends.

FA is used when connecting to a device that does not support FEF. If an FEF signal is sent to a device that does not support FEF, the device acts as if there is still a good connection. The FEF signal is mistaken for data. FA works similar to FEF, in that when there is a fault in one direction of the fiber, it acts on the fiber in the opposite direction. But unlike FEF, FA sends no signal. Because of this, FA can not be enabled on both ends. If it is enabled and a fault occurs, FA will turn signal off in the opposite direction; the device on the other side of the fiber will see the loss of signal and engage FA, turning off signal. The net result will be the signal turned off in both directions, even after the fault has been repaired.

It is highly recommended that only one is chosen, either FEF or FA. If both are selected FA will take precedence over FEF.

For more information on LinkLoss/FiberAlert, visit the IMC Networks Web site at <http://www.imcnetworks.com/support/> If unsure of how to implement these features in a specific configuration, contact IMC Networks Technical Support at (800) 624-1070 (U.S./Canada), +32-16-550880 (Europe) or via e-mail at: techsupport@imcnetworks.com.

Auto Negotiation on iMcV-LIM

iMcV-LIM modules include the feature Auto Negotiation. When Auto Negotiation is enabled, the module negotiates as a 100 Mbps full-duplex device. If the connected device can operate at 100 Mbps full-duplex, a link is established. Auto Negotiation (DIP Switch #1) is enabled by default.

If the twisted pair port on the other device does not have the ability to Auto Negotiate or if the 100 Mbps half-duplex connection is desired, then Auto Negotiation must be disabled. Half- and full-duplex settings must be set manually and match on both devices.

The following diagram shows a typical application and with three possible configurations.

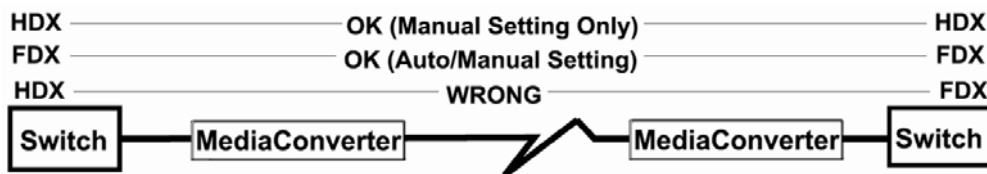

End-to-End Connection	Switch	TX/FX
Half-Duplex	Configure HDX manually	Auto Negotiation is OFF
Full-Duplex	Configure FDX manually	Auto Negotiation is OFF
Full-Duplex	Auto Negotiation is ON	Auto Negotiation is ON

Configure Auto Negotiation on an iMcV-LIM by adjusting the DIP Switch setting (for unmanaged modules) or via the management software. Refer to the DIP Switch table for switch location and settings.

AutoCross Feature for Twisted Pair Connection

All twisted pair ports on the iMcV-LIM includes AutoCross, a feature that automatically selects between a crossover workstation and a straight-through connection depending on the connected device.

LED Operation

Each iMcV-LIM module features diagnostic LEDs that provide information on features and ports.

FEF Glows green when a fiber end fault is detected.

TXLL Glows green when TX LinkLoss is enabled on the port.
Blinks when a fault occurs on the copper port and actively disables the fiber port.

LNK Glows green when fiber link is established.
Blinks green when activity is detected.

*** DIS** Glows amber when software is disabled on the TX port.

FA Glows green when FiberAlert is enabled.
Blinks green when active.

FXLL Glows green when FX LinkLoss is enabled on the port.
Blinks when a fault occurs on the fiber port and actively disables the copper port.

LNK Glows green when fiber link is established.
Blinks green when activity is detected.

*** DIS** Glows amber when software is disabled (via iView²) on the fiber port.

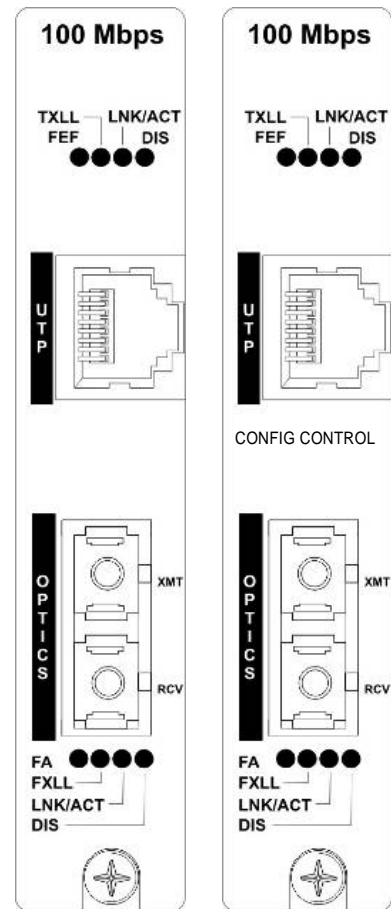

*For iMcV-LIM w/SFP and Configuration Control:

DIS indicates TX (copper) or TX (fiber) port is disabled either by DSW #7,8 or via iView². Refer to the DIP Switch matrix under Unmanaged Modules.

Installation Troubleshooting

- During installation, first test the fiber and twisted pair connections with all troubleshooting features disabled, then enable these features, if desired, just before final installation. This will reduce the features' interference with testing.
- When working with units where the features cannot be disabled, establish both the twisted pair and fiber connections before the link LEDs will light.
- To test a iMcV-LIM by itself, first, have an appropriate fiber patch cable, then follow these steps to test:
 1. Connect the iMcV-LIM to the twisted pair device with a twisted pair cable.
 2. Loop a single strand of fiber from the transmit port to the receive port of the iMcV-LIM.
 3. Verify that both the twisted pair and the fiber link are lit (see LEDs, below) on the iMcV-LIM.
- Use the appropriate twisted pair cable, and have the crossover/pass-through switch set correctly.
- Whenever possible, set the devices connected to the iMcV-LIM (hub, switch, NIC card) to the desired speed and Duplex setting, and turn Auto Negotiation OFF. Refer to Auto Negotiation on iMcV-LIM, also configure the devices on the opposite sides of the iMcV-LIM to operate at the same speed and Duplex setting.

NOTE
Some 10/100 devices can not be set by the end user, and must Auto Negotiate to receive a signal.

Specifications

Environmental

Operating Temperature

+32°F to +122°F (0°C to +50°C)

Storage Temperature

-13°F to +158°F (-25°C to +70°C)

Humidity:

5 - 95% (non-condensing)

DC Input

iMcV-LIM w/LFPT: 0.80 Amp @ 5V

Fiber Optic Specifications

For fiber optic specifications, please visit:

<http://www.imcnetworks.com/adocs/fcs.asp>

IMC Networks Technical Support

Tel: (949) 465-3000 or (800) 624-1070 (in the U.S. and Canada);
+32-16-550880 (Europe)

Fax: (949) 465-3020

E-Mail: techsupport@imcnetworks.com

Web: www.imcnetworks.com

Fiber Optic Cleaning Guidelines

Fiber Optic transmitters and receivers are extremely susceptible to contamination by particles of dirt or dust, which can obstruct the optic path and cause performance degradation. Good system performance requires clean optics and connector ferrules.

1. Use fiber patch cords (or connectors, if you terminate your own fiber) only from a reputable supplier; low-quality components can cause many hard-to-diagnose problems in an installation.
2. Dust caps are installed at IMC Networks to ensure factory-clean optical devices. These protective caps should not be removed until the moment of connecting the fiber cable to the device. Should it be necessary to disconnect the fiber device, reinstall the protective dust caps.
3. Store spare caps in a dust-free environment such as a sealed plastic bag or box so that when reinstalled they do not introduce any contamination to the optics.
4. If you suspect that the optics have been contaminated, alternate between blasting with clean, dry, compressed air and flushing with methanol to remove particles of dirt.

Electrostatic Discharge Precautions

Electrostatic discharge (ESD) can cause damage to any product, add-in modules or stand alone units, containing electronic components. Always observe the following precautions when installing or handling these kinds of products

1. Do not remove unit from its protective packaging until ready to install.
2. Wear an ESD wrist grounding strap before handling any module or component. If the wrist strap is not available, maintain grounded contact with the system unit throughout any procedure requiring ESD protection.
3. Hold the units by the edges; do not touch the electronic components or gold connectors.
4. After removal, always place the boards on a grounded, static-free surface, ESD pad or in a proper ESD bag. Do not slide the modules or stand alone units over any surface.



WARNING! Integrated circuits and fiber optic components are extremely susceptible to electrostatic discharge damage. Do not handle these components directly unless you are a qualified service technician and use tools and techniques that conform to accepted industry practices.

Certifications

CE: The products described herein comply with the Council Directive on Electromagnetic Compatibility (2004/108/EC).



**Class 1 Laser product, Luokan 1 Laserlaite,
Laser Klasse 1. Appareil A' Laser de Classe 1**

European Directive 2002/96/EC (WEEE) requires that any equipment that bears this symbol on product or packaging must not be disposed of with unsorted municipal waste. This symbol indicates that the equipment should be disposed of separately from regular household waste. It is the consumer's responsibility to dispose of this and all equipment so marked through designated collection facilities appointed by government or local authorities. Following these steps through proper disposal and recycling will help prevent potential negative consequences to the environment and human health. For more detailed information about proper disposal, please contact local authorities, waste disposal services, or the point of purchase for this equipment.

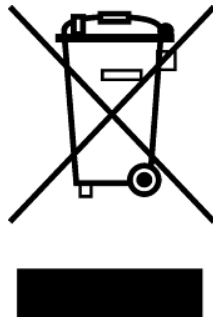



19772 Pauling • Foothill Ranch, CA 92610-2611 USA
TEL: (949) 465-3000 • FAX: (949) 465-3020
www.imcnetworks.com



© 2010 IMC Networks. All rights reserved.

The information in this document is subject to change without notice. IMC Networks assumes no responsibility for any errors that may appear in this document. iMcV-LIM is a trademark of IMC Networks. Other brands or product names may be trademarks and are the property of their respective companies.

Document Number 50-80921-00 A3

September 2010